

Till Jan-Olof med varmt tack för
all överdårig hjälp under arbetet
vän Kjell

LUND UNIVERSITY

DEPARTMENT OF LINGUISTICS

General Linguistics
Phonetics



WORKING PAPERS

30. 1987

KJELL NORLIN

**A PHONETIC STUDY OF EMPHASIS
AND VOWELS IN EGYPTIAN ARABIC**

LUND UNIVERSITY
DEPARTMENT OF LINGUISTICS

General Linguistics
Phonetics



WORKING PAPERS

30. 1987

KJELL NORLIN

**A PHONETIC STUDY OF EMPHASIS
AND VOWELS IN EGYPTIAN ARABIC**

ISSN-0208-526X

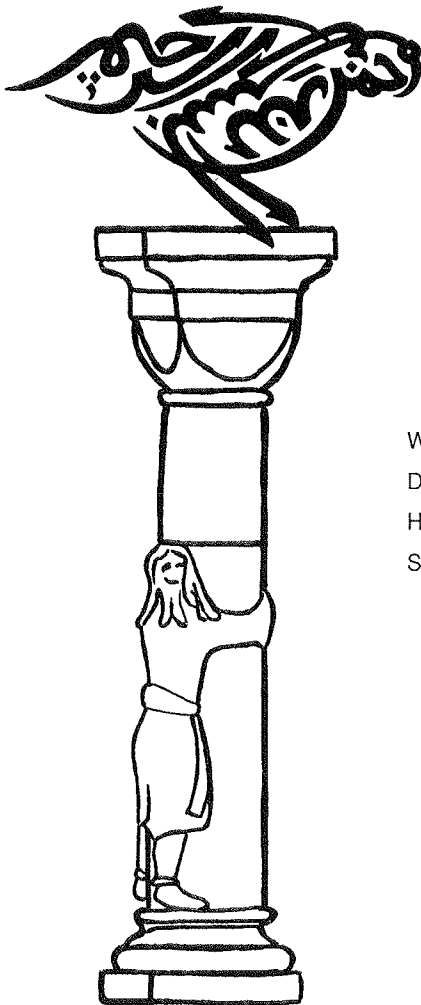

Working Papers
Department of Linguistics and Phonetics
Helgonabacken 12
S-223 62 LUND

To
Mona Lindau-Webb
David Webb
Nessa
Duchess
Vicky
Albert
and
Kaysar Cat

in whose company I have spent so many
lovely days
at home, at sea, at UCLA.

Latin är ett svårt språk, liksom svenska; svårare är grekiska; värre än grekiska äro de verkligt raffinerade krångliga språken, sådana som kinesiska och baskiska; men ojämförligt i sin svårighet är det fulländade språket, all invecklings och formrikedoms höjdpunkt, människotungors förtvivlan, Allahs eget tungomål, den ädla och underbara arabiskan.

Frans G. Bengtsson
i essän Gertrude Bell,
De långhåriga merovingerna.

Acknowledgements

This dissertation is one of the reports from a joint phonetic project (LUCLA) on three non-European languages run by the Department of Linguistics in Lund and the Phonetics Department at UCLA, Los Angeles. The project was sponsored by the Swedish Council for Research in the Humanities and Social Sciences. Professor Eva Gårding invited me to work with the Arabic part. I thank her for this opportunity and for her encouragement.

Professor Gösta Vitestam at the Department of Middle East Languages has shown a keen interest in my work and has welcomed this opportunity to interdisciplinary research. I thank him for his support.

Mona Lindau-Webb has been my supervisor and guide. She was probably a bull-mastiff in a previous life. Currently she is a superb dog trainer and an eminent linguist. How do I know? As a PhD in spe one is simply treated as an obstinate member of the species *Canis familiaris* and promptly brought to obedience training. Incited by an assorted array of sticks, carrots and a lot of patience one gets there in the end and can even be coerced to jump the fences. Thank you, dear!

Professor Peter Ladefoged and his wife Jenny opened both the Phonetics lab at UCLA and their home for me during my stays in Los Angeles. I had all the facilities of the lab at my disposal and Peter Ladefoged even altered his computer program of the vocal tract to suit my needs. In addition I received valuable comments and suggestions from him and his lab group. I enjoyed it so much. Thank you all!

Jan-Olof Svantesson has been my colleague in the LUCLA project. Collaboration with him has always been a pleasure and it has been even more so during the past months. He acted as a broad band filter and gave generously of his time to read the final drafts in order to prevent the camels to get through. His well founded but nevertheless tactful criticism led to substantial improvements in the final version for which I am most thankful. In addition his statistical knowledge and astounding dexterity in dealing with capricious computers have been invaluable.

Professor Gösta Bruce acted as a narrow band filter to strain out the gnats. It is amazing how many there were when one looked for them. I appreciate his suggestions and help.

As all phoneticians know, no filters are perfect. Camels as well as gnats might have slipped through. They are mine, of course.

David House corrected my English most skilfully and deprived linguists of some amusing examples of the use of his mother tongue as a second language. After obtaining his imprimatur I hope that at least the surface structure should be understandable.

I thank my colleagues at the Departments of Middle East Languages and Linguistics for help, encouragement and suggestions. My thanks to lab engineer Gustav Jönsson, who more than once disentangled me from the mess I made when connecting loudspeakers, computers, mingographs and what not.

I also wish to thank my informants, who suffered willingly long sessions of recordings. Their sighs, groans and comments on the tapes have been a source of amusement during the analysis. Hisham Bahari has been of particular help on several occasions.

When God created strawberries He could have made an even more delicious fruit, had He wanted to. We all know He did not. When God created woman He could have made someone even more wonderful than my wife Karin, had He wanted to, but He did not. She is behind it all.

CONTENTS

1. INTRODUCTION

- 1.1 The Arabic language and the Egyptian Arabic dialect.
- 1.2. The phonological system of Egyptian Arabic.
 - 1.2.1. Vowels and diphthongs.
 - 1.2.2. Consonants.
- 1.3. Syllables and syllable structures.
- 1.4. Stress
- 1.5. Outline of thesis

2. MATERIAL, INFORMANTS, METHODS.

- 2.1. Data set.
- 2.2. Informants.
- 2.3. Methods.

3. EMPHASIS.

- 3.1. Nature of emphasis and its treatment in the literature.
- 3.2. Review of the interpretation of emphasis.

4. PLAIN AND EMPHATIC SIBILANTS

- 4.1. Procedure
- 4.2. Results.
- 4.3. Discussion.

5. VOWEL QUALITY

- 5.1. Procedure
- 5.2. Results and discussion.
 - 5.2.1. Long plain vowels.
 - 5.2.2. Short plain vowels.
 - 5.2.3. Emphatic vowels.
 - 5.2.4. Long and short plain vowels.
 - 5.2.5. Long and short emphatic vowels.
 - 5.2.6. Comparison between plain and emphatic vowels.
 - 5.2.7. Long plain and emphatic vowels.
 - 5.2.8. Short plain and emphatic vowels.
 - 5.2.9. Comparison between vowel quality in Egyptian Arabic and some other dialects.

6. FORMANT TRANSITIONS

6.1. Procedure.

6.2. Results and discussion.

6.2.1. Shared traits in onset frequency between long and short vowels.

6.2.2. Long vowels.

6.2.3. Short vowels.

6.2.4. The phonetic and phonemic status of [e] and [o].

6.2.5. Treatment of short vowels in Egyptian dialects.

6.2.6. Short vowels in some other Arabic dialects.

6.2.7. Onset frequency in other Arabic dialects.

6.2.8. The importance of onset frequency and center frequency for emphasis.

6.2.9. Long /aa/ and short /a/.

7. MODELLING OF THE VOCAL TRACT

7.1. Procedure.

7.2. Results.

7.2.1. Results for F1-F2.

7.2.2. Results for F3.

7.3. Comparison with X-ray data.

8. DURATION.

8.1. Procedure.

8.2. Results and discussion.

8.2.1. Duration of plain versus emphatic vowels.

8.2.2. Long and short vowels.

8.2.3. Quantity in Egyptian Arabic and other languages.

8.2.4. Duration depending on the following consonant.

8.2.5. Intrinsic length.

8.2.6. Duration of intervocalic consonants.

APPENDIX.

TABLES 1-5.

BIBLIOGRAPHY

1. INTRODUCTION

1.1 The Arabic language and the Egyptian Arabic dialect.

The term Arabic covers a large spectrum of linguistic variation within a vast area in North Africa and West Asia. The Qurʾān and the form of Arabic it represents, manifested in a vast and diverse literature, has always been the object of an intense linguistic interest, first of all from Arab scholars of course, but soon enough from many others of different nationalities. The linguistic interest in Arabic is thus by no means a modern phenomenon, but dates back to the Holy Book itself and the work to edit an authorized version of it under the third Caliph ʿUthmān (644-56). Soon thereafter a number of sciences related to the Qurʾān flourished. They included grammar, lexicography and others intended to preserve and enhance the understanding of the message of the Qurʾān. Later incentives to linguistic studies during the establishment of the vast empire were of a political, administrative and commercial kind.

This formidable work of transforming the spoken language of mostly nomadic tribes in the Arabian peninsula into the written and spoken means of communication from the Pyrenees to Persia and beyond was mainly performed during the first centuries of Islam. The period from the 7th to the 10th century can be regarded as a golden age of Arabic linguistic science. For a more detailed survey of this period, see Chejne (1969). The outcome of this activity came to prescribe, up to the present day, how pure Arabic, "fuṣṣḥā", should be spoken and written. This kind of Arabic is still the current means of communication all over the Arab world and is the prestigious form of the language necessary to know for anyone who wants to study the rich cultural heritage of the Islamic world. It is grammatically intact, but has undergone an enormous expansion in its vocabulary during the last century, and has been influenced by the introduction of modern science, European literary genres and journalism (Monteil 1960, Hamzaoui 1965, Stetkevych 1970, Kropfitch 1978). A current English term for today's fuṣṣḥā is (Modern) Standard Arabic.

It should also be remembered that Arabic is the holy language of all Moslems, regardless of nationality. It has further had an enormous impact on the languages of countries which once belonged to the Arab empire or otherwise have been in close contact with it. Persian is one example of a language which has incorporated large parts of the Arabic vocabulary. Swahili is a Bantu language which has borrowed heavily from Arabic during centuries of commercial contacts.

The Arabic language and its literature has been studied for centuries in Europe and has lately received an intensified interest.

Beside the fuṣṣḥā, however, there have always existed a large number of vernaculars, differing on all levels of grammatical structure between themselves to the point of mutual unintelligibility in the extreme cases, and vis-a-vis fuṣṣḥā. Descriptions of the so called

diglossia are found in e.g. Altoma (1969), Diem (1974) and Talmoudi (1984). These vernaculars, or dialects, are the true mother tongues of all Arabs. They are spoken forms of Arabic only, and have with few exceptions, mostly dating from modern times, never been used for written communication. They have little prestige in comparison with fuṣḥā and are often considered to be degenerate and corrupt forms of Arabic by literate and illiterate speakers alike. Diem (1974:3f.) gives a long list of Arabic pejoratives, which label the dialects as inferior forms of speech in comparison to fuṣḥā. They have therefore been and are still the object of numerous attempts to "correct" them. There are for example an impressive number of works intended for mass circulation and dedicated to the eradication of words and grammatical constructions considered to be irreconcilable with fuṣḥā, (Diem 1974:6). While the linguistic interest in the Arab world is mainly focussed on fuṣḥā and the classical literature, a lot of work on the dialects by native speakers have been done abroad.

For a linguist these dialects are attractive and fascinating from several points of view. From a linguistic point of view they are full-fledged languages and of course in no way less suitable than fuṣḥā to serve as a means of communication. They are highly living, giving direct access to a speech community, to its literate and illiterate members alike.

The Arabic dialects are usually divided into an Eastern and a Western group. This partition was originally done by Arab scholars in the Middle Ages, who noted the linguistic differences between East and West and the affinities between the dialects in these parts of the empire. As early as the ninth century the geographer al-Muqaddasī remarked that Western dialects were not easily understood by an Arab from the East (Bakalla 1984:89). The differences are found on all levels: phonetically, morphologically, syntactically and lexically. As an example one can mention the common phenomenon of reduction of short vowels in the Maghrib, an area including Morocco, Algeria and Tunisia. Short /a/ and /i/ have merged into /ə/, and most dialects thus have only two short vowels. Short vowels in open syllables have been completely lost. Willms (1972) reckons with only one short vowel: /ə/. Syllable structures and stress patterns have been greatly affected in the process. The Western dialects have also borrowed heavily from surrounding Berber languages, as well as from French and Spanish during the last century. One detailed introduction to this dialectal area is Harrell (1962), who describes Moroccan Arabic. Assad (1978) gives a still more detailed description of the city dialect of Tetuan.

A survey of the dialects of the Arabian peninsula is found in Johnstone (1967). For some Bedouin dialects, see Palva (1980, 1986).

In the modern Arab world the Egyptian dialect, or more precisely, the dialect of the capital city Cairo, has a special position among the vernaculars. It is generally accepted, both in East and West, as a more prestigious dialect than the others (Fischer-Jastrow 1980:20,22). This linguistic importance of Egypt has an historical explanation. Cairo has

since its foundation in the tenth century, been one of the great cities in the Arab world and from the very beginning it has been an outstanding center of Islamic learning, attracting large numbers of students. The importance of Egypt and its dialect has been even more pronounced in modern times. One third of all speakers of Arabic live in Egypt. The country has long been a leading Arab nation in the political, military and educational fields. Its voice is widely heard nowadays in many ways; through broadcasting, a flourishing film industry exporting its popular products in the Egyptian dialect and through the presence of hundreds of thousands of guest workers of all professions in other Arab countries. It is also attracting more Arab students and visitors from abroad than ever before.

1.2. The phonological system of Egyptian Arabic.

1.2.1. Vowels and diphthongs.

The aim of this investigation is to provide a phonetic description of the vowel system of Egyptian Arabic. Like all Semitic languages it has relatively few vowels, but offers nevertheless a number of interesting phonetic and phonological problems, some due to the much discussed phenomenon of emphasis. There has so far been a general agreement on the inventory of vowel phonemes in Egyptian Arabic, the main peculiarity of which is the asymmetrical absence of short mid vowels. The long vowels form a five vowel system, which is a shared phonological property of all dialects east of Libya (Jastrow-Fischer 1980;56).

long vowels		short vowels	
ii	uu	i	u
ee	oo		a
	aa		

According to some descriptions, for example Abdel-Massih (1975;21) there are also short mid vowels, /e/ and /o/, but according to other sources, for example Fischer-Jastrow (1980;53), the system comprises only the three short vowels listed above. This problem will be discussed in chapter 6.

As will be shown below it is possible to find minimal pairs that demonstrate the opposition between all long vowels. Some contrasts are rarely used, however, and minimal pairs are difficult to find. The contrast /ii:/ee/ is not very common and the opposition /uu:/oo/

seems to be even more rare. A few examples exist. /ii/ contrasts with /ee/ in /diin/, 'religion' and /deen/, 'debt'. /uu/ contrasts with /oo/ in /moot/, 'death' and /muut/, 'die!'.

The opposition /ii/:/ee/ has an important morphological function in differentiating the masculine dual ending /-een/ from the masculine plural ending /-iin/. Considering the fact that the overwhelming majority of nouns and adjectives takes broken plural forms and plural formation by suffixes is relatively scarce, the contrast is seldom used.

Opposition between short vowels is in some cases hard to find. Contrast between /i/ and /u/ is for example rare. Woidich (1980) gives a few examples: /ʔulla/, 'water jar' contrasts with /ʔilla/, 'lack', and /gumaal/, 'beautiful', pl., contrasts with /gimaal/, 'camels'.

The long mid-vowels have developed historically from sequences of vowel + glide: ay>ee and aw>oo, (Fischer-Jastrow 1980:53). Examples of this process are /ʃayf/>/ʃeef/, 'summer', /xayr/>/xeer/, 'goodness', /lawn/>/loon/, 'colour' and /fawqa/>/fooʔ/, 'above'.

Egyptian Arabic also has three diphthongs, [iɪw], [aɪw] and [aɪj] as in /yiwʃil/, 'he arrives', /layla/, proper name, and /dawfa/, 'noise'.

These diphthongs are found in a number of isolated words, partly from Standard Arabic. In most cases they are found in conjugated forms of the verb, as in passive participles of weak verbs like /mawguud/, of /wagad /, 'to find', or active participles feminine singular of hollow verbs like /ʃayla/, of /ʃaal/, 'to carry', or in present tense forms of weak verbs, like /yiwʃil/, of /wiʃil/, 'to arrive'.

The following minimal sets illustrate the phonemic status of long and short vowels:

saar	'to walk'	sarr	'to please'
seer	'belt'	sirr	'secret'
suur	'wall'	surr	'please!'
loon	'colour'		
liin	'softness'		
beed	'eggs'		
biid	'white' pl.		
ʃoom	'fast'		
ʃuum	'fast!'		

1.2.2. Consonants.

The consonant system is as follows:

labial	dental	palatal	velar	uvular	pharyngeal	glottal
b	t d		k g	q		ʔ
f	s z	ʃ	x ɣ		ħ ʕ	h
	ṭ ḍ					
	ṣ ḏ					
m	n					
	l					
	r					
w		y				

The consonant system shows a number of interesting characteristics. One of them is the presence of emphatic consonants (see chapter 3 for discussion of emphasis). Emphasis is denoted in the text by the symbol \cdot (dot) under the consonants in question. Vowels in emphatic environment are also denoted by the same symbol on the formant charts in chapter 5 on vowel quality.

The primary place of articulation of the emphatic consonants is sometimes described as dental, sometimes as alveolar. Since a pharyngeal constriction is one articulatory correlate of emphasis it is possible that a certain retraction of the apex of the tongue follows. Gairdner (1925; 15ff.) classifies the emphatic consonants as alveolars, as does Abdel-Massih (1975;2). Harrell (1957;70) who paid special attention to the question found no tongue retraction during their articulation and consequently classifies them as dentals.

None used any experimental methods to decide the matter.

Marçais (1948;10f) used palatograms and X-ray pictures for a study of an Algerian dialect. The palatograms show a tongue retraction for emphatic /ṭ/ of about 8 millimeters, which makes it alveolar. The tracings of the tongue, based on X-ray pictures, also show tongue retraction for emphatics.

Ghazeli (1977;76) found a practically identical vocal tract configuration for plain and emphatic consonant pairs on X-ray pictures regarding the primary place of articulation. He could notice a slight difference in the position of the apex of the tongue which was usually a little more retracted for the emphatics. He could not connect this small difference in articulation with any noticeable acoustic consequences.

In view of the lack of experimental data for Egyptian Arabic the emphatics are listed here as dentals according to Harrell.

There is an unusually large number of fricatives (Norlin 1983) and the back places of articulation are used extensively. A bilabial voiceless stop is absent.

1.3. Syllables and syllable structures.

The syllable structures are limited in number and restricted to five different types: CV, CVC, CVV, CVVC and CVCC.

Further restrictions apply to the syllables in that the last two types only can occur in word final position (including monosyllables). No syllable can begin with a vowel and no syllable can begin with more than one consonant. Consonant clusters with more than two consonants are not allowed. To prevent clusters of three consonants at for example a word boundary, usually a short [i], or in some cases [a] or [u], is inserted, as in [giddina], 'our grandfather', from /gidd/, 'grandfather' and /na/, pronominal suffix, first person plural, [bintaha], 'her girl', from /bint/, 'girl' and /ha/, pronominal suffix, third person feminine singular and [katabtuhum], 'I wrote them', from /kataba/, 'to write' and /hum/, pronominal suffix, third person masculine plural.

Detailed phonological studies of syllable structures in Egyptian Arabic are found in for example Broselow (1976) and Selkirk (1981).

1.4. Stress

The position of stress within a word is predictable, as it depends on the syllabic structure of the word.

1. The following syllable types are always stressed when they occur in a word: CVV, CVVC and CVCC.

2. If a word contains or ends in a syllable sequence CVCVCV(C), the stress falls on the antepenultima.

3. In all other cases the stress falls on the penultima.

Examples:

	1.		2.
'jaalu	'they carried	'sufara	'ambassadors'
fa'luu	'they carried it'	'ṭalaba	'students'
ka'tabt	'I wrote'	'masalan	'for example'
mak'tuub	'written'		

	3.		
ʔis'taḥsin	'to approve of'		
muḥ'taram	'respected'		

A word cannot have more than one long syllable. If for various morphological reasons, for example affixation of personal pronouns, a word comes to contain two long syllables, the vowel of the first one is shortened and the stress is shifted as in the previous examples: /'ʃaalu/, 'they carried', and /ʃa'luu/, 'they carried it'. Further examples of this process will be given in the following chapters. A detailed description of shortening of long vowels and lengthening of short ones is given by Aboul-Fetouh (1969; 15f.).

1.5. Outline of thesis

The scope of this research is a phonetic investigation of emphasis and the vowel system in Egyptian Arabic.

The comparatively few vowels look rather uncomplicated on a phonological chart. However, as often is the case in languages with few vowel phonemes, the vowels display allophonic variations within rather wide limits. A strongly contributing factor to the different vowel qualities is the existence of emphasis, a phenomenon which is described as a process of velarization or pharyngealization in the literature. Occurrence of a vowel adjacent to one of the emphatic consonants influences its quality, in some cases to a very large extent.

Emphasis cannot be studied in a meaningful way as an isolated property of vowels. A general survey of emphasis will be given in chapter 3 after a presentation of material and informants in chapter 2.

Two plain and emphatic consonant segments will be treated and compared in chapter 4, where a method for investigating the spectral properties of fricatives will be presented. The spectral characteristics of /s/ and /ṣ/ and their voiced counterparts will be demonstrated. Other attempts to distinguish between plain and emphatic sibilants with different experimental methods will be discussed.

Chapter 5 is a treatment of vowel quality in plain and emphatic environment. The vowels will be presented in formant charts where their respective position in the acoustic space is demonstrated and the allophonic variation visible. The acoustic data obtained in this investigation will be compared with similar data from other Arabic dialects and interdialectal differences will be discussed.

Chapter 6 is a treatment of formant transitions, and their importance as a differentiating factor between plain and emphatic vowels in particular. The contributions of formant onset frequencies and formant center frequencies will be discussed.

Data from other Arabic dialects will be presented and the degree of prominence of emphasis in different dialects will be discussed.

The short vowels [e] and [o] will be investigated acoustically and their debated phonemic status will be discussed.

The special place of long /aa/ and short /a/ in the vowel system with regard to their very large variation in quality will be treated and the question of a possible phoneme split will be discussed.

Chapter 7 will deal with acoustic-articulatory relationships by introducing a model of the vocal tract. By manipulating its parameters acoustic data for velarized and pharyngealized configurations are predicted and will be compared with measured data obtained from the informants of this study.

Existing X-ray studies of various Arabic dialects will be compared with the predictions of the model.

Chapter 8, finally, is a treatment of durational properties of vowels and intervocalic consonants. The phonological implications of durational differences will be discussed and compared with other languages. Phenomena as intrinsic length and duration as related to following consonants will be discussed.

2. MATERIAL, INFORMANTS, METHODS.

2.1. Data set.

The data set illustrating plain and emphatic sibilants and vowels was selected from mostly real monosyllabic and disyllabic words. A minimum of trisyllabic words were included in the material to cover phonological and phonetic contexts not represented in the other words due to phonotactic restrictions of the language. In a few cases artificial words were incorporated to ensure identical phonological surroundings for all vowels. No informant rejected them or had any difficulty in producing them. Words including the long vowels /aa, ee, ii, oo, uu/ and the short vowels /a, i, u/ were recorded in syllables representing four phonological contexts. These phonological contexts are: CVVC, ÇVVC, ÇVVC̣, CVVC̣ and CVC, ÇVC, ÇVC̣ and CVÇ. These contexts makes a comparison possible between words in plain and emphatic contexts. To investigate the possibility of different formant patterns in CVVC̣ and CVÇ syllables as compared to the other emphatic environments, two informants recorded long and short vowels in these surroundings. Measurements and auditory checks showed that vowels in these types of emphatic syllables are not different from vowels in other emphatic environments. Emphasis is thus found to spread to the left as well as to the right of the emphatic consonants in Egyptian Arabic. This finding is in agreement with Card's (1983:49) results, obtained from Palestinian Arabic.

Additional material from more informants of CVVC̣ and CVÇ syllables was therefore not considered necessary and the acquired samples were not further considered in the investigation.

The appropriate test words are given in each chapter together with details on the number of syllables in the testwords, stress etc.

The vowels are preceded and followed by dental consonants in order to minimize movements of the formants due to coarticulation. Long /ee/ and /oo/ do not occur in long syllables surrounded by emphatic consonants and are therefore not represented in this context in the data.

All words are set in a sentence frame: *?ulna — kamaan*, (we said — again), thus avoiding the usual wordlist intonation of isolated items.

A word list containing all words used for the recordings is given in Appendix 1.

2.2. Informants.

Nine male, native speakers from Cairo, aged 25 to 55, were informants. Most of them have an academic education. A few were somewhat hesitant to record the material speaking Egyptian Arabic and would probably rather have preferred fuṣḥā.

The speakers recorded the sentences to give six tokens of each utterance. The first token of the six was not used in the investigation.

The test material was written on cards in Arabic orthography and read in random order. The informants were instructed to read at normal, conversational speed.

2.3. Methods.

The recording was made in the sound-proof studio of the Phonetics Department in Lund. Analysis was made from oscillogram wave-form and broad-band spectrograms from a digital spectrograph.

Paired t-tests were used to establish the level of significance of differences between sets of vowels and consonants when they could be supposed to have linguistic importance.

The measurements are listed in Tables 1-5, together with means, standard deviations and results of t-tests. Gaps in the columns depend on production errors or unmeasurable formants, particularly F3 of /uu/, /u/ and /oo/.

3. EMPHASIS

3.1. Nature of emphasis and its treatment in literature.

In order to optimize the number of phonemic oppositions, different languages use different strategies. Some of these strategies can be grouped under the label secondary articulations. Labialization and palatalization are for example well known phenomena. All variants of Arabic make use of a rarer form of secondary articulation, the exact nature of which has been the subject of much discussion. A widely used term for it is emphasis, which will be used in this investigation. Emphasis in both its acoustic and articulatory aspects caught the attention of the early Arab grammarians. That it is still considered a very characteristic feature by native speakers is revealed by one of the descriptive names Arabs have for their language. It is often called 'luḡat aḏḏāḏ', the language of ḏāḏ, the name of one of the four emphatic consonants. The Arabic-speaking peoples are also called 'ʔahl aḏḏāḏ', the people of ḏāḏ, because of this peculiar sound.

Not only Arabic, but all Semitic languages have or have had a series of emphatic sounds. Leslau (1957:325) distinguishes between two types of emphasis and discusses them and their place in Proto-Semitic. Emphasis is realized differently in Arabic and the Ethiopian languages of today. Arabic represents the velarized and pharyngealized type (Leslau mentions both articulations), whereas Ethiopian languages represent the ejective type. Opinions are divided on which type is Proto-Semitic. According to Leslau the ejective dental stops in Ethiopia are an influence from Cushitic languages, and he regards the Arabic type of emphasis as a Proto-Semitic heritage. For a recent phonetic comparison between emphatic dental voiceless stops in Arabic and ejective dental stops in Tigrinya, see Fre Woldu (1986).

Emphasis has traditionally, particularly by Arab grammarians, been regarded as a feature inherent in the emphatic consonants, which form an extra series of voiceless and voiced stops and sibilants, phonemically distinct from their plain counterparts. In the Arabic alphabet they are represented by distinct graphemes.

The following minimal pairs with plain and emphatic consonants in initial and final position demonstrate the phonemic contrast between them in Egyptian Arabic. Minimal sets with the consonant pairs in medial position also exist.

initial position:

tiin	'figs'	ṭiin	'mud'
darb	'lane'	ḏarb	'striking'
seef	'sword'	ṣeef	'summer'
zuhuur	'flowers'	ḏuhuur	'appearance'

final position:

baat	'to pass the night'	baaṭ	'armpit'
xadd	'cheek'	xadd	'to shake'
mass	'to touch'	maṣṣ	'to suck'
baaz	'falcon'	baaʒ	'to be spoiled'

The descriptions of emphatic consonants are not always very precise, as the one by Jomier (1964) who describes an emphatic /d/ as "un peu comme le 'dang' sonore et prolongé, qui veut imiter le son d'un cloche de cathedral". There has, however, been general agreement since the early days of the development of linguistics in the Islamic world that the so called emphatic consonants are produced by a secondary articulation with a distinctive function, consisting of a constriction somewhere in the back of the vocal tract, in addition to a primary dental/alveolar place of articulation. Sibawaihi (8th century) singles out the emphatic consonants in the phonetic description of Arabic in his 'al-Kitab', one of the foundations of classical Arabic linguistics (Bakalla 1984;34). There he ascribes articulatory gestures to them which are not a shared property by all back vowels, but peculiar to the emphatics as a class (Giannini, Pettorino 1982). Even if many scholars have found it difficult to pinpoint the exact meaning of his terminology and get a clear picture of his description, (e.g. Cantineau 1960), or simply dismiss them as confusing (e.g. Marçais 1948), many agree that the term velar seems to suit what he says about where the constriction occurs (Fleisch 1961;224, Giannini-Pettorino 1982, Bakalla, op. cit.). Modern investigators all agree with Sibawaihi on the existence of a secondary articulation causing the characteristic phenomenon of emphasis, whether they base their opinion on experimental studies or not, for example Harrell (1957), Tomiche (1964), Jastrow-Fischer (1980) in addition to those mentioned above.

The precise location of the secondary constriction in the emphatic consonants has been the subject of some argument, however. If one looks at the modern literature, ranging from teaching material, with often detailed descriptions of articulation with the ambition to elucidate this rare phenomenon and facilitate a correct pronunciation of it, to more scholarly presentations of Arabic and Semitic languages, one quickly finds that it is most often described as velar in the tradition of the ancient grammarians, both by native speakers of Arabic and others. As Obrecht (1968;20) says about the emphatic consonants: "...rather uniformly referred to as the velarized consonants." This is the case in Mattsson (1910), Gairdner (1925), El-Hajjé (1954), Cantineau (1960), Tomiche (1964), Nasr (1966), Ziadeh-Winder (1966), Abboud et al. (1968), Moscati et al. (1969), Beeston (1970), Fischer-Jastrow (1980). Sometimes it is described as pharyngeal as by Al-Ani (1970;44), Prasse (1971;IX), Talmoudi (1980;45), and sometimes as both as by Leslau (1957) and Abdel-Massih (1975). Mitchell (1978) does

not mention any constriction of any kind at a secondary point of articulation when he gives instructions about the pronunciation of the emphatic consonants.

On the whole it is not clear from the literature whether the choice is between these two alternative constrictions, or if both occur. Since emphasis is not only related to the emphatic consonants, but has an effect on adjacent vowel sounds as well, it is a possible hypothesis that different constriction locations can apply for a consonant and a following vowel, depending on what articulatory gestures are best for an economic coarticulation.

The modern dialects show a wide spectrum of phonemic contrasts in their segments, both among themselves and vis-a-vis Standard Arabic. It should by no means be impossible that emphasis, although certainly a universal phenomenon in all forms of Arabic, might be realised in different ways and degrees in different dialects (Fleisch 1961:224.), thus yielding different acoustic results or even that it is disappearing as a distinctive feature in some cases, at least in some phonetic contexts. It has undergone changes in the historical development of the dialect. /q/ remains in Egyptian Arabic as a shared phoneme with Standard Arabic, but has in many words developed into /z/. Just as changes in the phonemic inventories has occurred, it is quite possible that articulatory gestures connected with emphasis also have changed. Further, it appears that emphasis is not a completely rule-governed feature within the linguistic system only. Emphasis also seems to have paralinguistic functions and can even be related to sex (Kahn 1975). More puzzling is that its distinctive function maybe is not always so important as it is generally supposed to be. According to one informant in the present investigation at least some of the minimal pairs used to illustrate the opposition between plain and emphatic words can be heard in Cairo in free variation and that the difference is not clearly upheld even in other cases.

A number of valuable works have been published on other dialects than Egyptian Arabic. These will be compared with the findings of the present investigation to give a more complete picture of this phenomenon in the Arabic speaking area.

Granted that the view on emphasis as an inherent feature of the consonants is correct, emphasis causes each vowel to have two allophones, one "emphatic" when preceded or followed by an emphatic consonant, and a "plain" allophone, found in other environments. The difference in vowel quality between plain and emphatic allophones is large for some vowels, but small for others (see chapter 5 on vowel quality).

Emphasis as a phonetic phenomenon is not restricted to the consonantal segment alone, but expands over a larger domain, at least a syllable (Harrell 1957, Fleisch 1961). Not only is vowel quality affected within wide limits, but also consonant to vowel and vowel to consonant formant transitions show a great variety in degree, from large differences to such small changes that their perceptual significance

can be doubted. The articulatory correlates of these acoustic phenomena have been much discussed on the basis of results obtained by various techniques, e.g. X-ray pictures (Ali-Daniloff 1972, Ghazeli 1977, Giannini-Pettorino 1982, Wood 1982), electromyographic investigations (Kuriyagawa et al. 1986), tracings of lip-rounding and protrusion (Adem 1983). These correlates have been interpreted in various ways in the literature.

In this investigation the influence of emphasis on vowel duration, formant frequencies and formant transitions is described. Furthermore, a vocal tract model developed by Peter Ladefoged is used. Within this model the effects of different types of secondary articulation can be predicted, and these predictions are compared to the actual data obtained for Egyptian Arabic emphatic vowels in order to see which kind of secondary articulation gives the best fit.

Although the main point of interest in the present investigation is the vowel system, it is necessary in this context to deal with the nature of emphatic consonants, since vowels cannot be described without consideration of contiguous emphatic consonants because emphasis is never confined to a single segment. Here the treatment of emphatic consonants will be restricted to /ṣ/ and /ẓ/, since these sibilants are part of the phonological contexts, which form the object of the present research. These sibilants could further be expected to display interesting spectral characteristics that stop consonants do not have. The emphatic stop consonants can also be expected to show the same transitional characteristics between C and V as the sibilants and would most likely not give additional information bearing on the subject.

3.2. Review of the interpretation of emphasis.

Different approaches have been suggested for analyzing emphasis on the phonological level. Not everybody dealing with the problem has an optimistic view of finding a solution to the intricate questions which are connected with this feature in an abstract analysis. According to Drozdik (1973) the prevailing state of affairs is "that the problem of whether emphasis is a distinctive feature of consonants or that of vowels has not been satisfactorily solved." He is not even certain that it is possible to present a solution. He adds that the problem is "crucial and apparently unsolvable."

Drozdik's statement of the problem in this way indicates in fact one of the main alternatives in the suggested analyses, namely the treatment of emphasis as a phenomenon on the segmental level. With all its variations this approach can be said to be a development of the classical tradition. Those who argue for a segmental analysis regard emphasis as an inherent feature of a segment, but not necessarily of the emphatic consonants, as the Arab grammarians would have said, even if the majority of investigators seem to do so (Drozdik 1973). One Egyptian dialect (Khalafallah 1969) has been described as having

emphatic vowels with emphasis as a redundant feature of the consonants.

Those who argue for the segmental analysis, thus mostly regard emphasis as an inherent feature of the emphatic consonants, the influence of which spreads to adjacent segments due to coarticulation. With various suggested modifications this interpretation can be said to be in line with the classical tradition. The direction of emphatic influence, whether to the right or left, its range of spread, syllabic, polysyllabic or comprising whole words, and its degree, articulatory and acoustically, are factors subject to variation between different dialects.

In view of the difficulties to define the feature emphasis in segmental terms as belonging to either consonants or vowels the other alternative interprets emphasis as a prosodic feature. Among those, who argue for this approach are Harrell (1957) and Lehn (1963). For this approach it is a primary concern to define the domain of emphasis. Both regard the syllable as its minimal domain. Card (1983:80) rejects the prosodic analysis. She advocates a modified traditional analysis and regards emphasis as spreading throughout a whole word from a phonologically emphatic segment. This spread can be prevented under certain circumstances in Palestinian Arabic which she investigated, for example by high front consonants or vowels having a high F2.

The phonological interpretation of emphasis is mainly outside the scope of this investigation which aims at an analysis on the phonetic level of the vowel system where emphasis will be treated in different aspects.

4. PLAIN AND EMPHATIC SIBILANTS

Arab grammarians have traditionally assigned the distinctive feature of emphasis to consonantal segments, although emphasis has been shown always to have a larger domain than one segment. Their analysis has found its expression in giving the emphatic consonants distinctive graphemes in the alphabet.

The following analysis is an investigation of the plain and emphatic sibilants of Egyptian Arabic, the voiceless /s/ and /ṣ/ on the one hand, and the voiced counterparts /z/ and /ẓ/ on the other. Unfortunately, the acoustic properties of fricatives are difficult to describe. As Hughes and Halle (1956) found, the acoustic structure of fricatives varies within wide limits between individuals. This is stated once more by Ladefoged and Maddieson (1986:59), who add that it is still not known with any certainty what is constant, nor what is linguistically and perceptually most relevant. They assume that important factors, especially for sibilants, are the overall intensity, the frequency of the lower cut off point in the spectrum, the center of gravity and dispersion of the spectral components above a certain threshold. These parameters are described in the present investigation and makes it possible to compare the pairs of plain and emphatic sibilants within each other and give a picture of their position within the fricative space of Egyptian Arabic.

4.1. Procedure

The investigation of the spectral properties of plain and emphatic sibilants is based on six informants. All Egyptian Arabic fricatives have been described elsewhere (Norlin 1983) and in this investigation only the plain and emphatic sibilants will be presented.

The word-list regarding this particular subset of the data was read twice by each speaker. The analysis was made from the second reading. The sibilants were all pronounced in real words in word-initial position in the same carrier sentence as the rest of the material, preceded by short /a/ and followed by long /aa/, (...a-Caa). The following test words were used for the experiment:

saadis	'sixth'	ṣaadiʔ	'just'
zaakir	'mentioning'	ẓaalim	'tyrant'

Using the ILS program package, fast Fourier transform (FFT) spectra were made from a sample of the duration 26.5 milliseconds taken after the first third of the sibilant. The sampling frequency was 10 kHz, but by running the tape at half speed when sampling, it was increased to 20 kHz. These FFT spectra were converted to critical band

spectra according to the method described by Schroeder et al. (1979). This method gives a more correct representation of the spectrum according to what is known about the peripheral auditory system of man. The critical band spectra were measured twice with an interval of three months. The result of the second measurement was practically the same as at the first one.

Schroeder defines the critical bands by the formula:

$$f_n = 650 \sinh(n/7).$$

f_n stands for the upper limit of band n .

The spectrum can thus be described as consisting of 24 bands with bandwidths of about 100 Hz below 500 Hz and of approximately 1/6 of the center frequency above 1000 Hz. The following critical bands have been computed by the above formula:

n	f_n	n	f_n
1	93	13	2031
2	188	14	2357
3	287	15	2732
4	392	16	3136
5	505	17	3658
6	628	18	4228
7	764	19	4884
8	915	20	5640
9	1086	21	6512
10	1278	22	7516
11	1497	23	8674
12	1746	24	10010

The mean level in dB within each critical band was calculated. The spectra were then redrawn as histograms with each critical band represented as a bar with constant breadth and with the base-line at -30 dB. In this way the spectra are remodelled to an auditorily more correct form, since each critical band equals the same distance (1.5 mm) on the basilar membrane, or 1200 primary nerve fibers (Schroeder et al. 1979).

The low frequencies in band 1 cannot be measured with any exactitude by this method. Consequently only bands 2-24 were considered in the investigation.

The critical band spectra have been analyzed in terms of the spectral center of gravity and dispersion, as well as the mean intensity level in dB. For this purpose the following formulas were used, quoted from Svantesson (1986):

$$\text{center of gravity: } m = \sum_{n=2}^{24} n * 10^{(X_n/10)} / F$$

$$\text{dispersion: } s = \left(\sum_{n=2}^{24} (n-m)^2 * 10^{(X_n/10)} / F \right)^{1/2}$$

$$\text{mean intensity level: } x = 10 \log (F/23)$$

$$\text{where } F = \sum_{n=2}^{24} 10^{(X_n/10)}$$

and x_n is the mean level in dB in band n , as estimated from the FFT spectra.

The center of gravity is a measure of the overall pitch level of the spectrum, i.e. a lower center of gravity means a lower overall pitch. The dispersion can be considered as a measure of its flatness, i.e. a larger dispersion means a flatter spectrum.

Duplex oscillograms along with intensity and F0 curves were used for analyzing non-spectral properties of plain and emphatic sibilants. Spectrograms were also inspected for cues for this difference.

4.2. Results.

Table 1 gives the center of gravity of the critical band spectra, measured in critical band units and also given in Hz, the dispersion and the mean intensity level (dB). The mean intensity level is given as deviations from the average for each series of all Egyptian Arabic fricatives read on the same occasion. This makes them roughly comparable also between other speakers.

The acoustic parameters of the sibilants are displayed in figures 1-6. Figures 1 and 2 show their position within the fricative space.

In figure 1 the center of gravity for each fricative is plotted against the dispersion, thus representing the fricative space of Egyptian Arabic in a way which enables comparison with other languages. Figure 1 gives the mean values of the six speakers. In figure 2 the fricative space is represented in another form. The center of gravity is plotted against the mean intensity level over the critical bands. Figure 2 gives the mean values of the six speakers. In figures 1 and 2 the fricatives are kept rather well apart, even if the distance between /s/ and /š/ on the one hand, and /z/ and /ẓ/ on the other, is rather small. There is overlapping between individual speakers and particularly between occurrences of /s/ and /z/ and their emphatic counterparts, which for one speaker even have the opposite position as

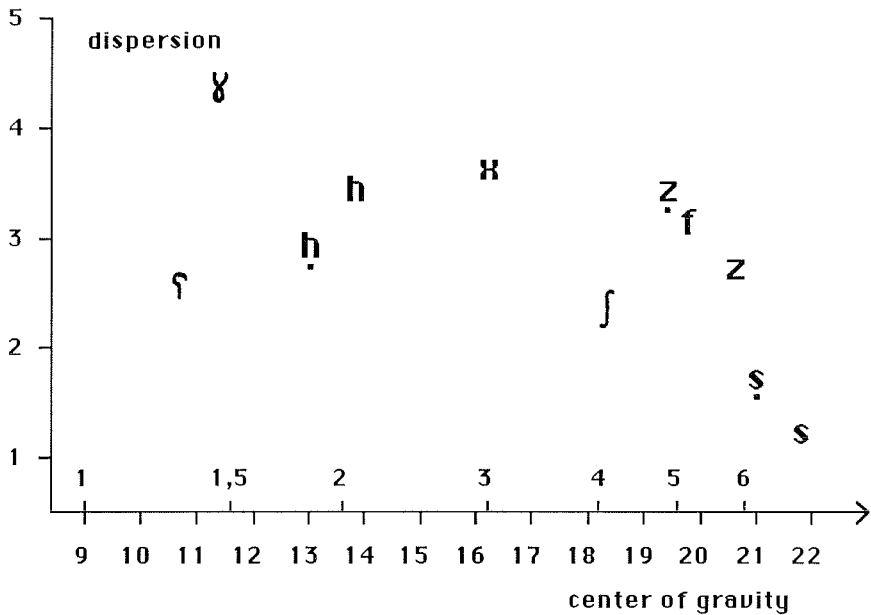

**Figure 1. Center of gravity against dispersion.
Mean values of six speakers.**

indicated by the mean values in the figures. One must therefore suppose that perception of fricatives involves normalization between different speakers.

Figures 3-6 show critical band spectra of the sibilants. /s/ and /ʃ/ are characterized by a sharp peak in the higher frequency ranges, band 21-23 (6500-8500 Hz), and an abrupt fall towards the lower ranges. Figures 3 and 4 shows that the peak of /ʃ/ is somewhat broader than that of /s/. For the sake of illustrating this, the histograms in the figures show the production of speaker 6, as he makes a rather large spectral distinction between /s/ and /ʃ/. For other speakers it is difficult to see the difference in histograms, but the difference can be detected by measuring the spectra, as is shown in Table 1.

Table 1 shows that /ʃ/ has its center of gravity in lower frequency ranges than /s/, with one exception, speaker 1. It also has a greater dispersion. The difference is not excessively large, but significant ($p < 0.01$) and corresponds well to the slight, but quite noticeable audible difference of these sounds in that /ʃ/ does not have the same high pitched quality as /s/.

/z/ and /ʒ/ both have a substantial peak of energy in the bands 3-6, in addition to the high frequency peaks of /s/ and /ʃ/ as can be seen

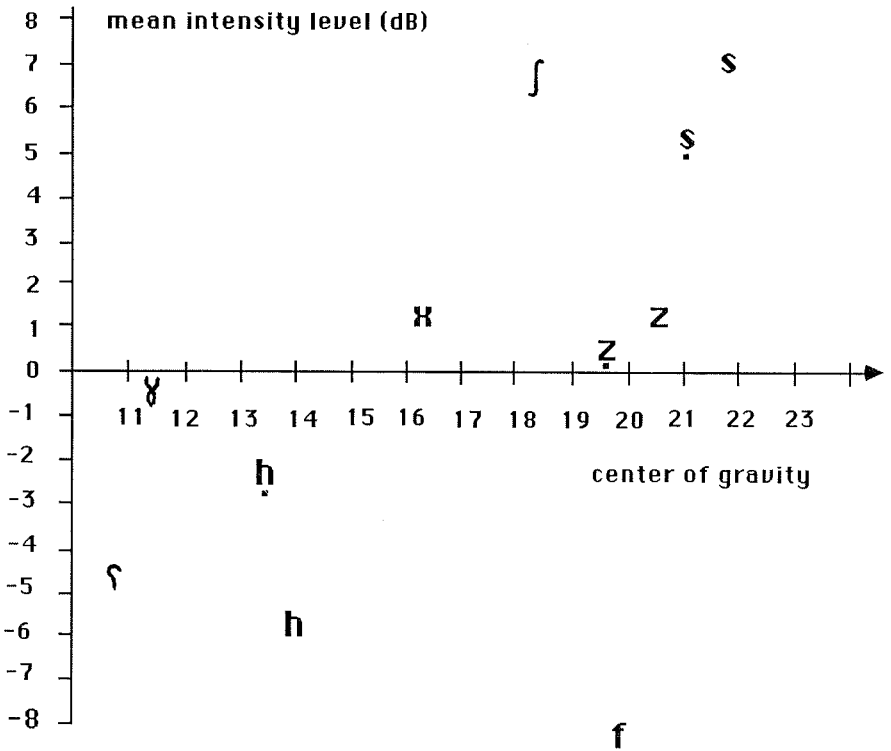

Figure 2. Center of gravity against mean intensity level.
Mean values of six speakers.

by comparing the histograms of figures 5 and 6. The former pair has lower intensity. The peaks in the lower bands depend on voicing. The concentration of energy in both ends of the spectrum, together with a cut in the top frequency range as compared to /s/ and /ʃ/ make their centers of gravity lower than that of their voiceless counterparts. Because of the energy peak in the lower bands there is a strong tendency for /z/ and /ʒ/ to have greater dispersion than /s/ and /ʃ/. For speakers 4 and 5 the relationship between center of gravity and dispersion of /z/ and /ʒ/ is reversed as compared to all others.

The difference between center of gravity in critical band spectra is the only quantitative measure found in this investigation, which differentiates between plain and emphatic sibilants. Inspections of intensity and wave-form on mingograms have not revealed any obvious differences between these sounds, nor can any difference be seen on spectrograms.

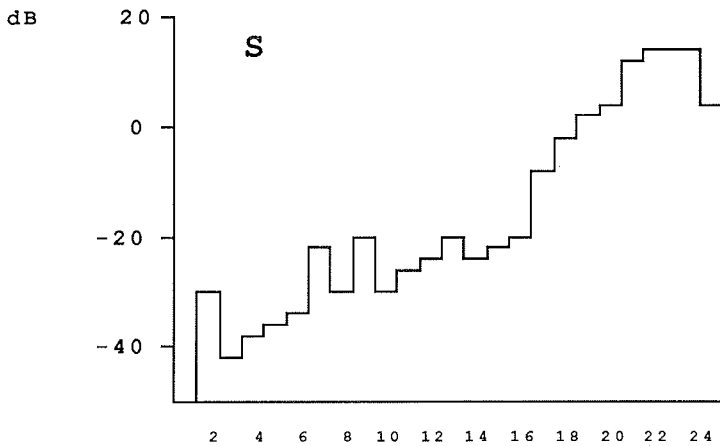

Figure 3. Critical band spectrum of plain /s/.

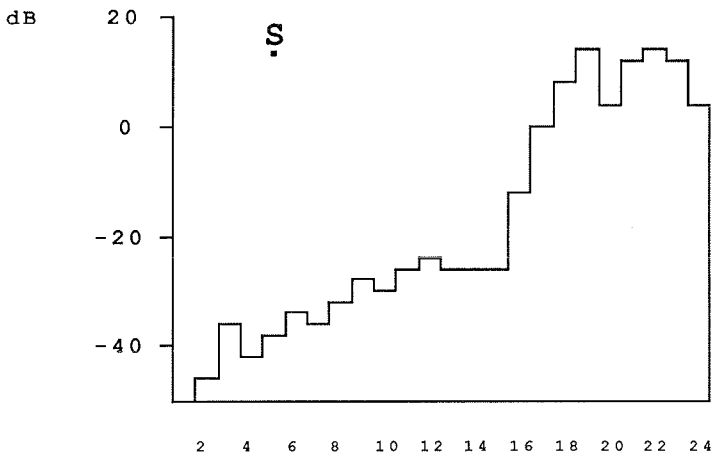

Figure 4. Critical band spectrum of emphatic /s/.

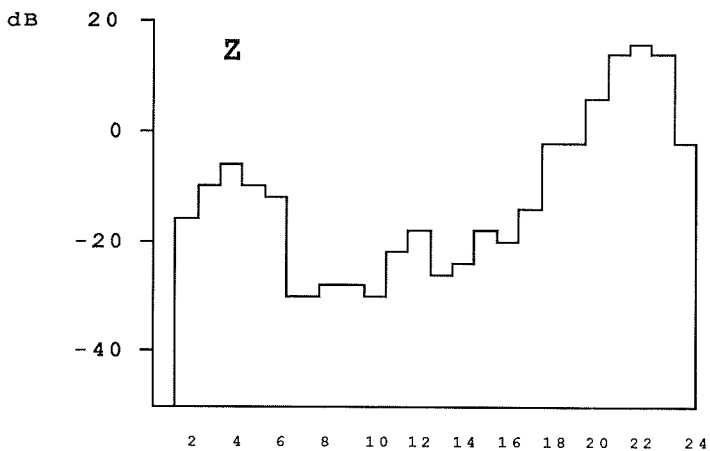

Figure 5. Critical band spectrum of plain /z/.

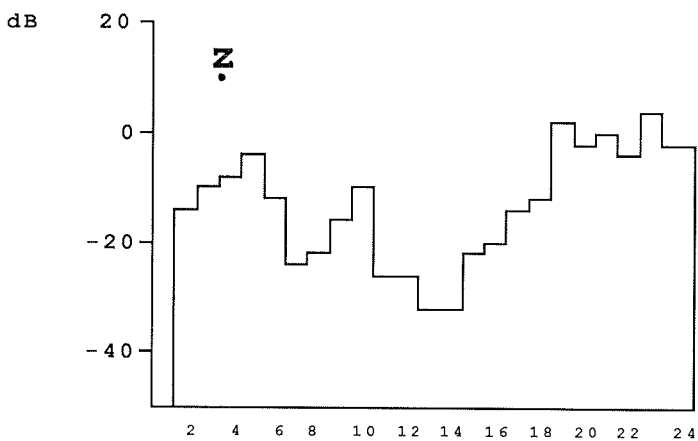

Figure 6. Critical band spectrum of emphatic /z/.

4.3. Discussion.

Nartey (1982) investigated the spectral properties of Egyptian Arabic fricatives in an intra- and interlinguistic investigation. His method made use of critical band spectra in a way similar to the one in the present research, which makes the results comparable.

In Nartey's investigation plain and emphatic voiceless sibilants were recorded in monosyllabic nonsense words preceding and following /a, i, u/, which were set in a sentence frame. In the comparison between /s/ and /ʃ/, Nartey found a spectral peak for one of the lower critical bands of /ʃ/ and related its presence to a possible additional pharyngeal source.

By superimposing the critical band spectra of /s/ and /ʃ/ for each vowel context, it is clear that there is a shift of acoustic energy from higher to lower frequency ranges for /ʃ/ as compared with /s/. This is particularly obvious when the sibilants surround /a/ and /i/. The difference between /s/ and /ʃ/ surrounding /u/ was found to be very small.

This small, and maybe nonsignificant difference between the consonants in the context of /u/, is parallel to the relatively small differences in frequency for the vowel /u/ in plain and emphatic contexts, which was found in the present investigation. The properties of vowels, regarding center and onset frequencies, will be treated in chapters 5 and 6.

The results of the present research thus confirm the findings of Nartey, concerning the existence of measurable differences between plain and emphatic sibilants in Egyptian Arabic, although this investigation was performed with only one vowel context.

In most cases it seems to be impossible to find any information on spectrograms that could distinguish between /s/ and /ʃ/. Al-Ani (1970:46f.) claims to have been able to separate /s/ and /ʃ/ on spectrograms. The lower cut off point in the spectrum for /s/ was approximately at 3000 Hz, and around 2750 Hz for /ʃ/.

Obrecht (1968:34) could distinguish /s/ and /ʃ/ from /ʃ/ on spectrograms, but nothing that singled out /ʃ/ from /s/.

In the investigation of Giannini and Pettorino (1982) the authors came to the same negative results at inspection of spectrograms and mingograms, as no properties of emphatic sibilants were detected, which distinguish them from plain ones.

Card (1983) also looked for cues for emphasis on spectrograms, but found it impossible to correlate emphasis with the bottom cut off frequency. Sometimes /s/ showed friction all the way through the spectrum, while /ʃ/ only had friction in the higher regions. Kahn (1975) also found that /ʃ/ could have friction at higher frequencies than /s/ on spectrograms.

Although spectrograms in principle give the same information as critical band spectra, they obviously do not give enough details to make it possible to differentiate between plain and emphatic sibilants.

Fre Woldu (1981) investigated also some non-spectral properties of emphatic and non-emphatic consonants in speakers from Algeria and Tunisia. Here reference is made only to the results concerning the sibilants. Measurements of the intraoral air pressure showed that speakers differed in their absolute values of the pressure, but the magnitude of difference between emphatics and non-emphatics proved to be the same for each speaker. Peak intraoral air pressure in H₂O was identical for /s/ and /ṣ/ and thus does not give any cue to the differentiation between them.

Subsequent experiments with a photoelectric glottograph yielded the same negative results. No systematic distinction could be seen between the glottal opening for any plain and emphatic obstruents.

Analysis of computer analyzed fundamental frequency curves showed that there are no significant differences in F₀ in the vowels following plain and emphatic consonants.

The perceptual importance of the existing differences between voiced and voiceless plain and emphatic sibilants respectively is difficult to decide. Perceptual tests are few. The notorious difficulty for non-Arabs to distinguish between them in pronunciation and perception when learning Arabic has probably its explanation in the phonemic categorization in Arabic, where the untrained ear only can hear allophonic variation. It is still not clear, however, whether an Arab can differentiate between plain and emphatic sibilants on the difference in the noise spectrum alone. Obrecht (1968;35) found that this is impossible with /s/ and /ṣ/ without transitional information in a vowel segment.

5. VOWEL QUALITY

In this chapter the quality of plain and emphatic long and short vowels will be described and compared. Data from other Arabic dialects will be presented and compared with the results.

5.1. Procedure

The following set of words was used for measuring formants in their center frequencies:

long vowels:		short vowels:	
saad	'govern'	sadd	'close'
zeet	'oil'	zetha	'her oil'
siid	'lord'	sitt	'lady'
looz	'almonds'	lozha	'her almonds'
suud	'black' (pl.)	sudd	'close!'
ṣaad	'to hunt'	ṣadd	'to prevent'
ṣeed	'hunting'		
ṣiit	'reputation'	ṣitt	artificial word
ṣoot	'voice'		
ṣuud	artificial word	ṣudd	'prevent!'
ʔiṣaaṣ	'punishment'	ʔiṣaṣha	'her stories'
taxṣiiṣ	'specialization'	ʔaṣiṣha	'he punished her'
maxṣuuṣ	'special'	ʔuṣuṣha	'her coccyx'

When possible, monosyllabic words were selected for formant measurements. In the instances where phonological restrictions of the language made this impossible, disyllabic and trisyllabic words were chosen. Vowels in ÇVVC environment are represented in disyllabic words since vowels do not occur in monosyllables in this context. Short vowels in CVC context are represented in trisyllabic words, formed by adding personal pronoun suffixes to a disyllabic noun or verb. This makes the stress fall on the second syllable containing the investigated vowel.

In all cases the stress is on the syllable with the investigated vowel.

Formant frequencies were measured from a steady state portion of the vowel. The center frequencies of the first three formants of the five tokens of the investigated vowels were traced and superimposed on each other to get an idea of the variation within each speaker. Within each speaker the variation of F1 and F2 proved to be very small, around

25 Hz, and can in all cases be considered to be within the measurement error. F3 showed a slightly greater variation. Because of the within-speaker consistency of formant frequencies only three tokens from each speaker were selected for analysis, except for /uu/, where five tokens were measured due to weak higher formant patterns in some cases. The measurements were checked again eight months later and proved to be consistent.

The long and short vowels were all found to be monophthongs (with the possible exception of [e] and [o], to be discussed later). Mean formant values representing each vowel of each speaker were calculated. These are listed in Table 5:1-10. A lab computer program, developed by Ladefoged (1985), was used to plot the values of F1 against F2 and F1 against F3 in Hz on a mel scale. Furthermore, the program draws 95 % tolerance areas, i.e. ellipses that have centers on the mean formant frequency for each vowel and axes that are oriented along the principal components of the formant distributions for each vowel, and on the average encompass 95% of the values in each cluster (Disner 1982).

The plots are given in Figures 7-16.

Some difficulties were found with some speakers to measure the center frequency of F2 and F3 for long plain and emphatic /uu/ and in some cases /oo/ because of weak or non-existing formant patterns on the spectrograms. These cases with unmeasurable formants have been neglected in the investigation and are indicated by empty spaces in Tables 5:5,6,9 and 10.

5.2. Results and discussion.

5.2.1. Long plain vowels.

Figure 7 is a formant chart of the five long, plain vowels. They form well separated clusters, except for long /ii/ and /ee/, where some slight overlapping occurs. In comparison with the other vowels on the chart, long /aa/ has a great variation in frequency in the F1 dimension. F1 varies within roughly 225 Hz, from 500 Hz to 725 Hz. In comparison with /aa/, the other vowels have much smaller variation in the F1 dimension, ranging between 70 and 100 Hz. In the F2 dimension long /aa/ has frequency variations within the same range as in F1, roughly 230 Hz. The other vowels have greater dispersion in frequency in F2 than in F1. The most notable ones are /ii/, which has mean F2 values from 2085 Hz to 2685 Hz, a range of 600 Hz, and long /ee/, whose F2 varies from 1900 Hz to 2415 Hz, a range of 515 Hz. These variations are reflected in the orientation of the ellipses on the chart, but one has to keep in mind that the mel scale expands F1 compared to F2.

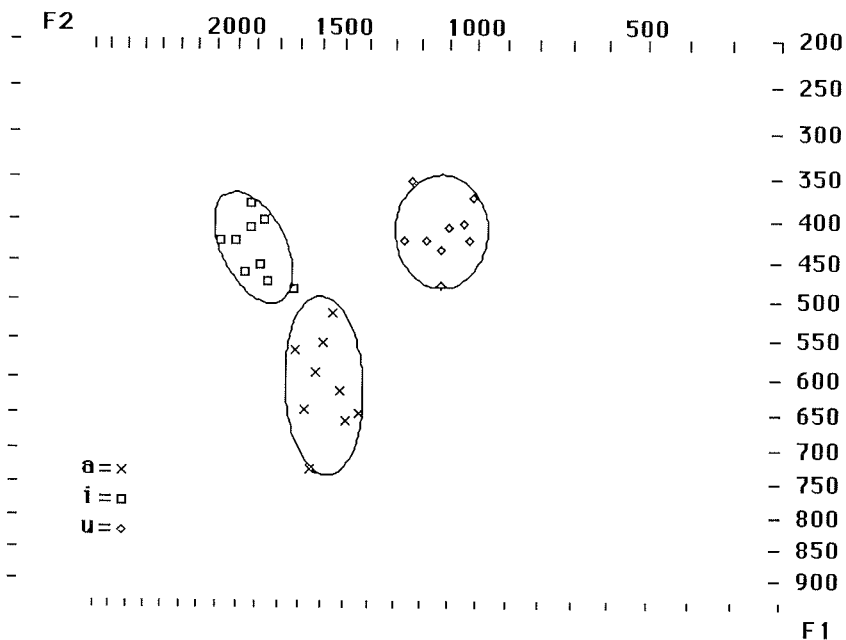

Figure 8. Plain, short vowels.

5.2.3. Emphatic vowels.

The picture of the long and short emphatic vowels is a bit more complicated. Since long /ee/ and /oo/ do not occur between emphatic consonants, some gaps necessarily must occur. The emphatic long vowels /aa, ij, uu/, and their short counterparts, were investigated in two phonological contexts, C____C, and C____C. Comparisons by paired t-tests do not show any significant differences between long vowels in these two environments, in either the onset or the steady state portion of F1 or F2. The only exception is /uu/, which does not display any differences between formants in the onset, (for onset frequencies, see the following chapter), but shows a significant difference in F2 of the center frequency, ($p < 0.01$), Table 5:5. Repeated and careful measurements consistently gave this unexpected result. F1 and F3 of the steady state do not differ, on the other hand. With the exception of /uu/, the long vowels have not been treated separately in the two emphatic contexts, but have been collapsed and the ellipses on the formant charts thus represent 18 tokens. Emphatic /uu/ is represented by two ellipses, one for each phonological context. Long /ee/ and /oo/, which do not occur in C̣VVC̣ or C̣VC̣ syllables, are investigated in emphatic environment in

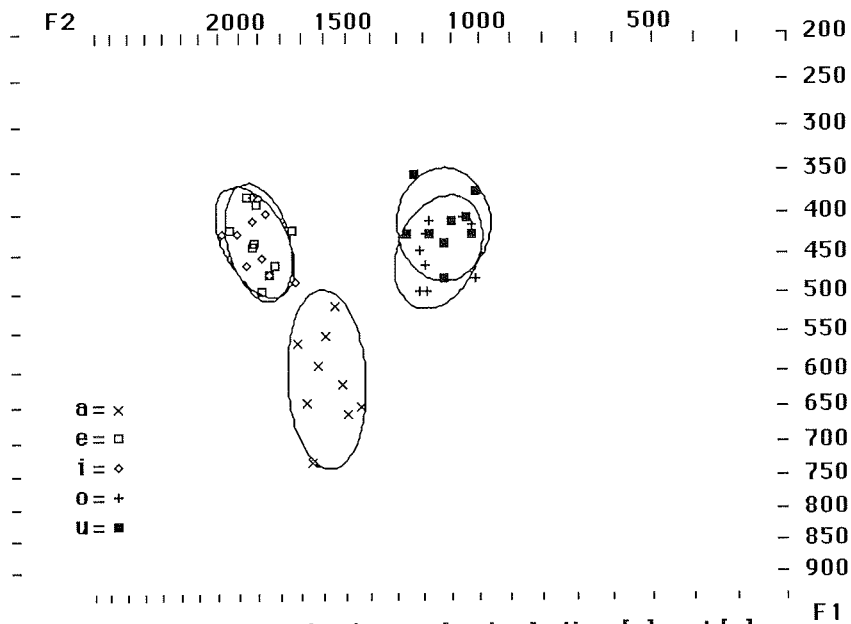

Figure 9. Plain short vowels, including [e] and [o].

CVVC and CVC syllables only. The ellipses of these vowels thus represent nine tokens.

None of the three short vowels differs significantly in the two emphatic contexts, with the exception of /i/ where F1 has a low significant difference, ($t=2.644$, $p<0.05$, 6 df). Due to an accident in the recording of the material, two informants are not represented. The significance level must be considered too low to allow far-reaching conclusions regarding the consistency of the language on this point. All tokens of short /i/, i.e. from both emphatic contexts, have therefore been collapsed into one ellipse. The other short vowels have likewise been collapsed into one single ellipse for each vowel.

Figure 10 shows the long, emphatic vowels. They form five clusters, but not quite so well separated as the plain ones. /ii/ and /ee/ show a greater overlapping than their plain counterparts, and /uu/ and /oo/ overlap to a certain extent, whereas their plain counterparts are well separated. There is in other words an approachment between high and mid vowels in the F1 dimension in emphatic environment. Long /uu/ in the CVVC context shows the same characteristics as other emphatic vowels compared with plain ones, with a slightly raised F1, lowered F2 and raised F3. Long /uu/ in CVVC context shows the same changes in F1

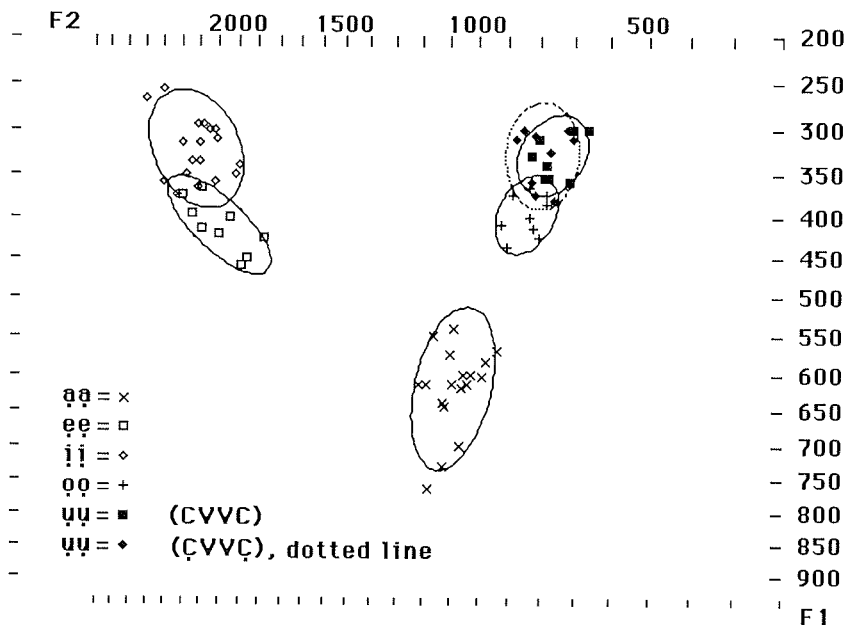

Figure 10. Long emphatic vowels.

and F3, but F2 remains on the same level as in plain context. Thus long /uu/ in the two emphatic surroundings shows differences in F2 only.

Figure 11 shows the three short emphatic vowels forming well separated clusters with no overlapping.

5.2.4. Long and short plain vowels.

Figure 12 shows the plain long and short vowels plotted on the same formant chart. Long /ii/ and /uu/ are outside their short counterparts in the acoustic space, as long vowels are in many other languages, for example in Czech and Swedish (Gårding 1974:29) and Hausa (Lindau 1985). Short /i/ and /u/ are centralized, /i/ being lower and further back than /ii/, and /u/ being lower and more front than /uu/. Short /a/ is not centralized as the other short vowels compared with long /aa/. The difference in F1 is nonsignificant and there is thus no difference in vowel height. A centralized short /a/ could have been expected, since this is a common tendency. Short /a/ is not always centralized,

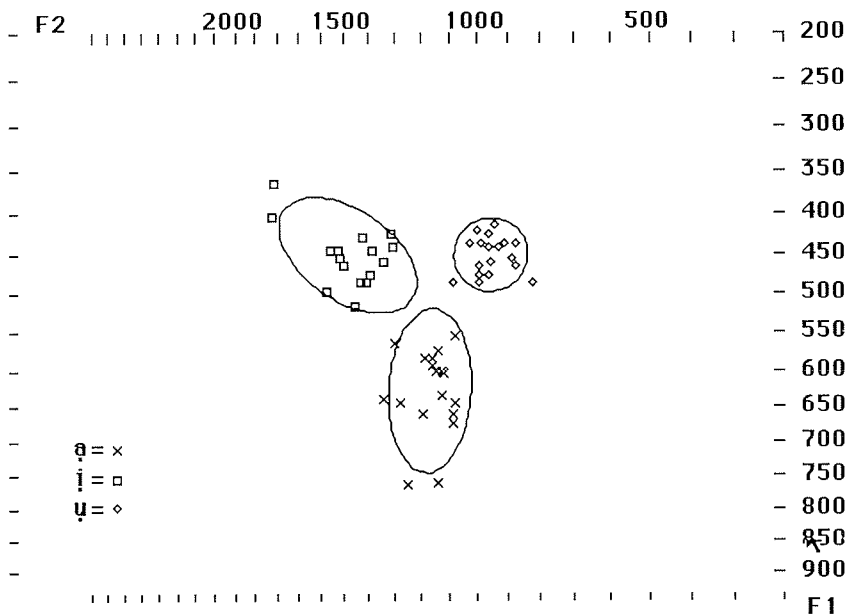

Figure 11. Short emphatic vowels.

however. It is in Czech, for example, but in Swedish, Serbo-Croatian and other languages long /aa/ is lower than short /a/ (Gårding op.cit.). In Egyptian Arabic there is no difference at all. /aa/ and /a/ differ significantly in F2 only ($p < 0.01$), short /a/ being further back.

5.2.5. Long and short emphatic vowels.

Figure 13 shows the long and short emphatic vowels. As noted above, short [e] and [o] are not investigated in emphatic environments and therefore not included in the charts. The chart shows that high, short vowels are centralized in the same way as the corresponding plain ones. /i/ is lower and further back than /ii/, /u/ is lower and more front than /uu/. Emphatic /aa/ and /a/ overlap even more than the corresponding plain vowels. The difference in F1 is nonsignificant and the significance level of the difference in F2 is low ($p < 0.05$). Thus the vowel quality of emphatic /aa/ and /a/ is very much the same.

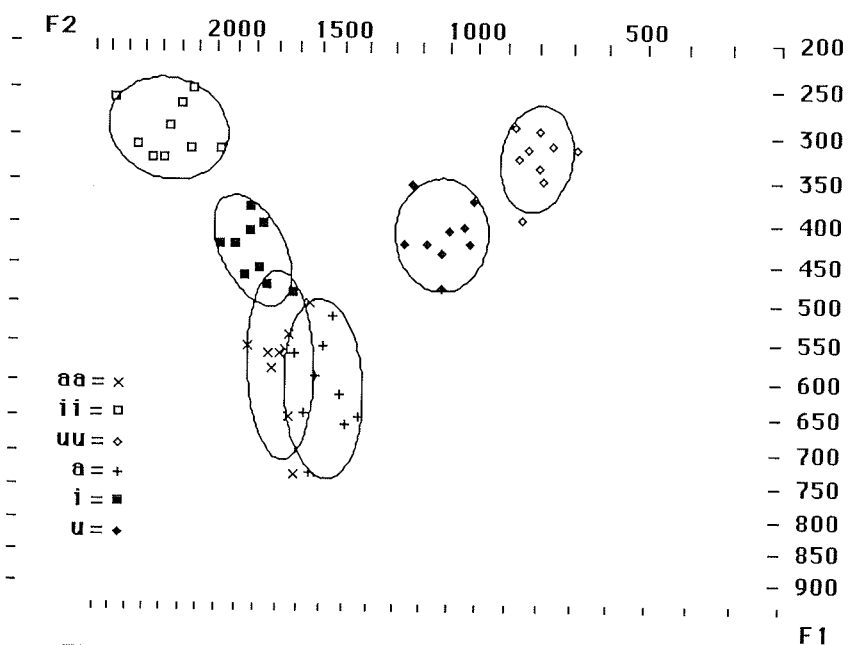

Figure 12. Plain long and short vowels.

5.2.6. Comparison between plain and emphatic vowels.

Mean values of center frequencies in plain and emphatic environment together with the difference between the two sets were calculated are listed in the following table:

		plain	emphatic	diff.(emph.-plain)
/ea/	F1	585	620	35
	F2	1780	1085	-695
	F3	2625	2650	25
/ee/	F1	385	410	25
	F2	2215	2100	-115
	F3	2800	2735	65
/ii/	F1	295	325	30
	F2	2365	2220	-145
	F3	3070	2810	-260
/oo/	F1	405	400	-5
	F2	880	845	-35
	F3	2415	2665	250
/uu/	F1	305	330	25
	F2	790	ÇVVC: 765	ÇVVC: -25
			ÇVVC: 795	ÇVVC: :5
	F3	2375	2640	265
/a/	F1	615	630	15
	F2	1585	1165	-420
	F3	2615	2660	45
/i/	F1	435	450	15
	F2	1915	1485	-430
	F3	2610	2595	-15
/u/	F1	415	450	35
	F2	1120	955	-165
	F3	2430	2485	55

Table 5-A. Formant center frequencies for nine speakers in plain and emphatic environments and the difference between the two contexts.

Two-tailed t-tests, Table 5, were used to test whether there were any significant differences in vowel quality, measured as the center frequency of the formants, in different emphatic environments, i.e. ÇVVC and ÇVVC. In addition, t-tests were used to find whether there were any significant differences in vowel quality between plain vowels and the two emphatic environments, respectively. The difference between long and short vowels within each phonological context was also investigated by two-tailed t-tests, when overlapping ellipses on the

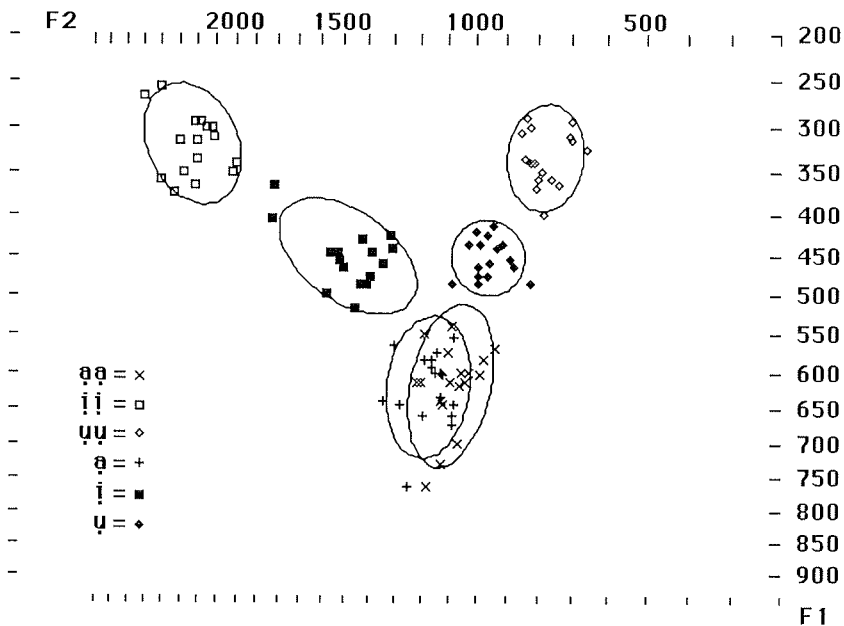

Figure 13. Emphatic long and short vowels.

acoustic charts did not show a separation wide enough to decide the matter by eye.

Long plain and emphatic vowels are shown in two separate figures for the sake of clearness.

5.2.7. Long plain and emphatic vowels.

Figure 14 compares the long plain and emphatic vowels /aa, ii, uu/. The picture of acoustic parameters differentiating the two sets of vowels is quite complicated and includes differences in vowel quality or formant transition onset or a combination of both. This question will be treated in chapter 6 on formant transitions. The shift from plain to emphatic /aa/ alters the vowel quality drastically, however, and is most easily detected auditorily, even by an untrained ear.

Figure 15 shows all plain and emphatic long vowels, including /ee/ and /oo/. Due to limitations in the amount of data accepted by the computer program the emphatic vowels are restricted to the CVVC type of syllable.

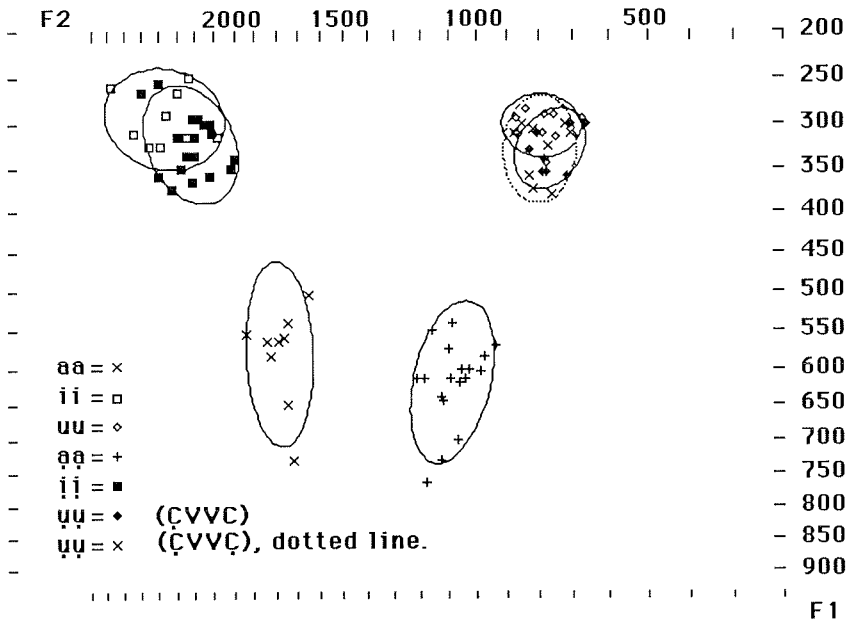

Figure 14. Long plain and emphatic vowels.

There is a considerable overlapping between the plain and emphatic allophones of front and back mid vowels. Long /ee/, however, shows significant differences in both F1 and F2, ($p < 0.01$, Table 5:7). Long /oo/ has nonsignificant differences in both F1 and F2 and a low significant difference in F3, ($p < 0.05$) and thus has the same quality in plain and emphatic environment.

The t-tests show that the vowel sets differ in degrees of significance. Regarding vowel quality long /aa/ has a highly significant difference between plain and emphatic contexts, long /ee, ii/ have a less prominent degree, whereas long /oo, uu/ have none or a small one. The smaller differences in vowel quality are compensated for by increased differences in transition onsets. The influence of emphasis on the quality of the long vowels seems to be related to the features high-low and front-back, so that high vowels are affected less than low vowels, and front vowels more than back vowels.

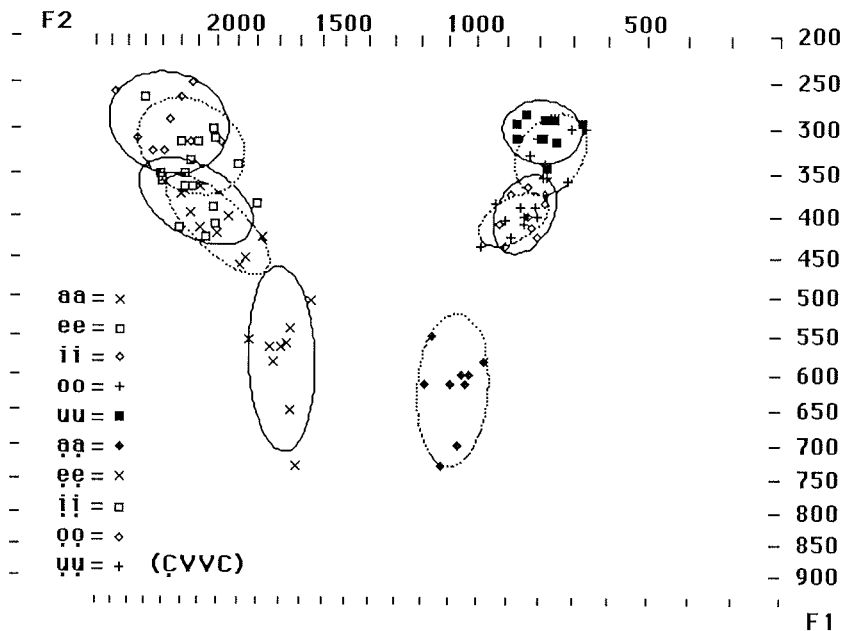

Figure 15. All long, plain and emphatic vowels.

Dotted ellipses=emphatic vowels.

5.2.8. Short plain and emphatic vowels.

Figure 16 finally, compares the short plain and emphatic vowels. The two vowel sets are clearly separated from each other with very little overlapping, in contrast to their long counterparts. All emphatic short vowels are considerably further back in F2, where the difference is highly significant, ($p < 0.001$) for all vowels. Short emphatic /i/ and /u/ differ slightly in F1 from the plain counterparts, ($p < 0.05$), whereas emphatic /a/ does not show a significant difference from plain /a/. The distinction between plain and emphatic contexts is thus upheld clearer between the short vowel sets than between the long ones. One possible explanation for this can be that the distinctive feature for emphasis is primarily a consonantal property as has been shown in the section on sibilants. During the articulation of a long vowel the coarticulatory influence of an emphatic consonant on an adjacent vowel has time to decrease. The vowel consequently approaches formant values, which are near those targets, which are typical for plain vowels. In the case of

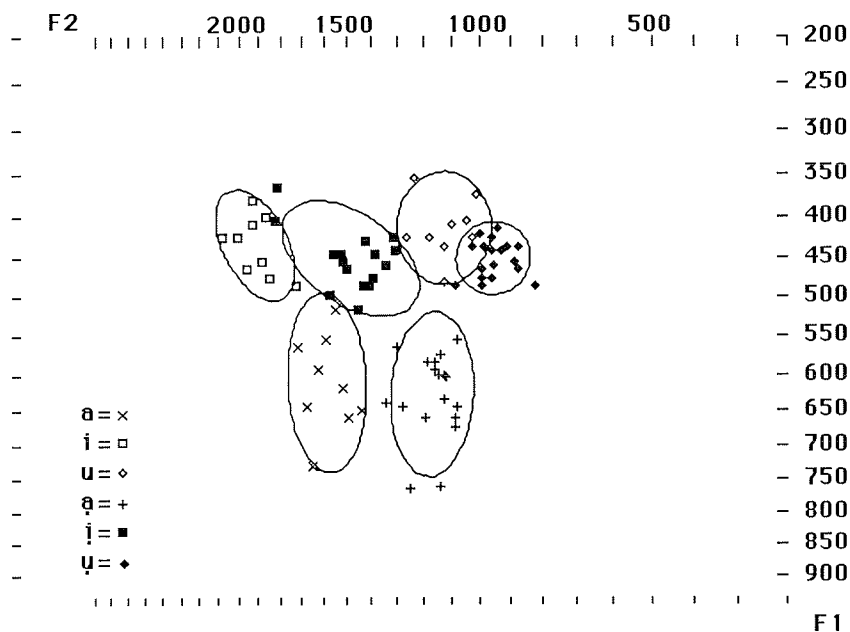

Figure 16. Short plain and emphatic vowels.

short vowels this cannot happen, because during its short time span of articulation the coarticulatory effect of emphasis remains through the vowel, which thus cannot reach its target value.

5.2.9. Comparison between vowel quality in Egyptian Arabic and some other dialects.

Although available data on formant frequency values from different Arabic dialects are not immediately comparable because of the widely differing sets of test material, which are structured to fit different aims, it is nevertheless possible to make rough comparisons and get some idea of dialectal variations. The present investigation does not cover cases where emphasis occur secondarily, and all vowels are set in a dental/alveolar context to minimize formant movements. This is not the case in Card (1983), who investigated emphasis in all its manifestations in Palestinian Arabic and where the consonantal contexts influences formant frequencies. Card presents mean center frequencies for each one of four speakers in her Tables 1-6 (pp. 37-42). Computing the mean value of each vowel for these speakers makes her

results comparable with the present study. The following table shows the F2 drop in emphatic environment for Palestinian and Egyptian Arabic.

	Palestinian Arabic	Egyptian Arabic	
/aa/	-345	-695	
/ii/	-85	-145	
/uu/	-50	-25	ÇVVC
/a/	-300	-420	
/i/	-305	-430	
/u/	-285	-165	

Table 5-B. F2 drop in emphatic environment in Palestinian and Egyptian Arabic for long and short vowels.

The comparison shows that emphasis affects the quality of most Egyptian Arabic vowels to a much larger degree than is the case in Palestinian Arabic. The only exceptions are long /uu/ and short /u/ where Palestinian Arabic has larger drops in F2 than Egyptian Arabic. The difference is small for the long vowel, but considerably greater for the short one.

The large differences between Palestinian Arabic and Egyptian Arabic might seem surprising, but the large drop in F2 center frequencies appears to be a characteristic property of Egyptian Arabic. Ghazeli (1977;61) lists center frequencies for /aa/ for a number of dialects, mostly North African, but also for Cairene and Jordanian Arabic. The drop in F2 for Egyptian Arabic is 650 Hz, close to the average in this investigation. The drop in F2 for Jordanian Arabic, which is linguistically close to Palestinian Arabic, is 300 Hz, the same value as found by Card. Only one other dialect, in southern Tunisia, mentioned by Ghazeli (op.cit.) has a slightly larger drop in F2 than Egyptian Arabic. The others drop only by 250-450 Hz.

Obrecht (1968;28f.) has data on center frequencies for one speaker of Lebanese Arabic. In some words in his material the consonantal context is not dental/alveolar, which makes an immediate comparison with Egyptian Arabic difficult in some cases, but the tendency is quite clear. Vowel quality is very little altered in emphatic environment as compared with plain surroundings. The expected drop in F2 center frequency is small or non-existent for all long and short vowels, except for /aa/ and /a/. For /ii/ and /i/, for example, there is no difference at all, whereas there is a drop for both in Egyptian Arabic, the drop for /a/ being quite large.

The low vowels /aa/ and /a/ are the only ones, which are substantially altered in their whole length in emphatic environment in Lebanese Arabic. The degree of lowering differs somewhat from

Egyptian Arabic. For long /aa/ the drop, measured between labial consonants, is 950 Hz, which is more than in Egyptian Arabic. The F2 drop for short /a/, measured between dentals, is 300 Hz, which is less than in Egyptian Arabic.

Giannini-Pettorino (1982) investigated Iraqi Arabic. The data are based on one informant only. Formant frequencies are not listed in tables, but it is obvious from the figures that Iraqi Arabic display both differences and similarities compared to Egyptian Arabic. The long vowels do not seem to differ much between plain and emphatic environment in Iraqi Arabic. Emphatic long /aa/ is roughly 200 Hz lower in F2, which is close to what Ghazeli (op.cit.) reports for the same dialect. Emphatic long /ii/ is about 150 Hz lower in F2. This drop is the same as in Egyptian Arabic. F2 drops very little for emphatic /uu/ as it does in Egyptian Arabic.

The differences in F1 between plain and emphatic environment are very small for all long vowels in Iraqi Arabic, as they are in Egyptian Arabic, but show the same tendency to rise slightly.

The only large difference between long vowels in the two dialects are the /aa/ qualities in plain and emphatic environment where Egyptian Arabic has much lower center frequency.

The differences between plain and emphatic short vowels are much greater in Iraqi Arabic, as it is in Egyptian Arabic. The differences in frequency are very much the same for the two dialects, except that F1 seems to rise more for emphatic /i/ and /u/ in Iraqi Arabic and that F2 drops considerably more in Egyptian Arabic for emphatic /a/.

Al-Ani (1970) investigated the acoustic properties in what appears to be Standard Arabic according to the phoneme chart. The informants were Iraqis, and for some contexts two Jordanians, but the chart (op.cit. 29) does not contain any typical consonant phonemes for these dialects. The speakers' underlying dialect is clearly at work however. The formant charts reveal more about the acoustic properties of Iraqi and Jordanian Arabic than any supposed standard form of the language. They can therefore be used for interdialectal comparisons.

The relatively small drop in F2 for vowels in emphatic environment in Iraqi Arabic, as reported by Ghazeli (op.cit.;61) and Giannini-Pettorino (op.cit.;figs. 6-8) ought to result in considerable overlapping between plain and emphatic vowels, particularly for /aa/ and /a/ in Al-Ani's investigation. This is also the case. There is possibly a greater difference between plain and emphatic /ii/ than in the other studies.

As expected, the short vowels show greater differences between plain and emphatic surroundings than the long ones, except that the two sets of /a/ are closer than in Egyptian Arabic.

Available data make a comparison between Egyptian Arabic and other dialects very selective. Data exist for /aa/ and /a/ for a comparatively large number of dialects, but based on few speakers. It is obvious that Egyptian Arabic makes an unusually large difference in quality for these low vowels in plain and emphatic contexts.

For the rest of the vowels the data available for comparison are limited. The differences between Iraqi and Egyptian Arabic do not seem to be very large. In comparison with Palestinian Arabic, emphatic vowels in Egyptian Arabic are characterized by a more pronounced drop in F2.

6. FORMANT TRANSITIONS

Formant transitions have been shown to have a crucial importance in the decoding of the speech signal. Their acoustic structure gives information not only of the vowel itself, but are cues to the correct identification of adjacent consonants. It has become clear through perceptual tests that listeners can identify different consonants depending on the formant transitions alone, even if no consonantal segment is present in the speech signal (Delattre et al. 1955, Denes and Pinson 1973;174f.).

Formant transitions have long been recognized to be highly important in connexion with emphasis in Arabic. Several studies, for example Ghazeli (1977) and Card (1983), to name some of the latest, have shown the characteristic patterns, particularly the large drop in F2 onset frequency. Emphasis has also been studied in experiments with perceptual tests, based on synthetic speech (Obrecht 1968).

Thus, since not only steady state properties of vowels are known to play a perceptual role, long and short vowels were measured also in their onset frequencies. The relevance of the differences in the onsets versus center frequencies between the sets of plain and emphatic vowels will be discussed. The importance of formant transitions for the short vowels [e] and [o] will be treated in connexion with a discussion of their phonemic status.

Some differences between Arabic dialects on the segmental level are easily detected at an auditive comparison between different vowel sounds. One can suppose that part of this variation depends not only on vowel quality, but also on formant transitions. A comparison will be made between Egyptian Arabic and other dialects for which data are available.

6.1. Procedure.

The following set of test words was used for measuring formants in their onset and center frequencies, i.e. the characteristics of formant transitions between consonant and vowel.

long vowels:

saad	'govern'
zeet	'oil'
siid	'lord'
looz	'almonds'
suud	'black' (pl.)

ṣaad	'to hunt'
ṣeed	'hunting'
ṣiit	'reputation'
ṣoot	'voice'
ṣuud	artificial word

ʔiṣaaṣ	'punishment'
taxṣiiṣ	'specialization'
maxṣuuṣ	'special'

short vowels:

sadd	'close'
zetha	'her oil'
sitt	'lady'
lozha	'her almonds'
sudd	'close!'

ṣadd	'to prevent'
ṣitt	artificial word
ṣudd	'prevent!'

ʔiṣaṣha	'her stories'
ʔaṣiṣha	'he punished her'
ʔuṣuṣha	'her coccyx'

To investigate in what contexts and to what degree formant transitions are a factor in the differentiation between plain and emphatic vowels in Egyptian Arabic, transitions of long and short vowels were measured in syllables of the three phonological structures mentioned previously, namely CVVC, ḤVVC, ḤVVC̣ and their short counterparts. Measurements were made on the same three spectrograms, which were used for the investigation of vowel quality. The starting point of the transitions, considered to be the onset frequency of the formants in the beginning of the vocalic segment, was measured and mean values calculated. The mean values of formant onsets and mean center frequencies are shown for nine speakers for long and short vowels in figures 17 and 18. The onset and center frequencies of each vowel are connected and thus show the direction of formant movement. Transitions are measured in initial position only, between C and V. Transitions between V and C were not measured, since they were expected to show the same characteristic patterns as in initial position.

Onset frequencies and mean values for nine speakers are listed in Table 4.

Paired t-tests were used to establish the difference between the transitions of plain and emphatic vowels. The results are also listed in Table 4.

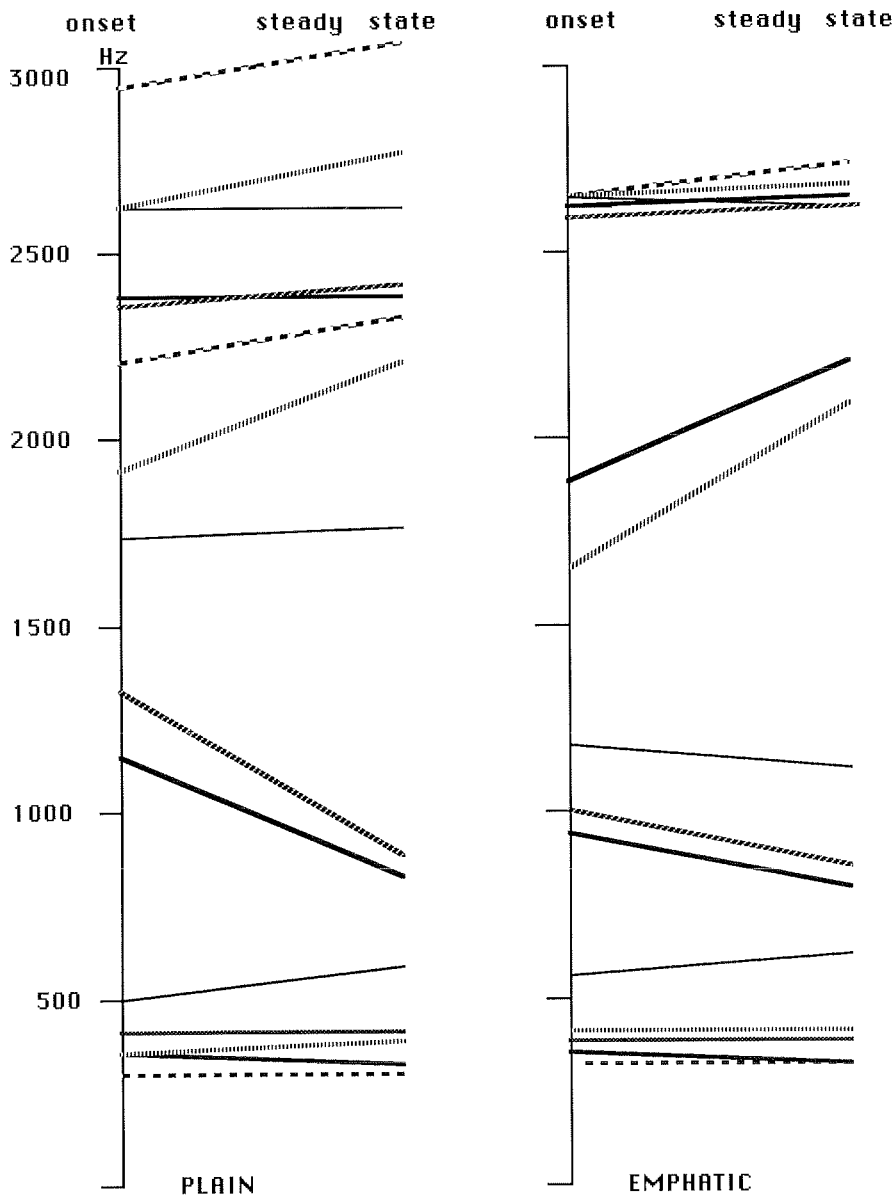

Figure 17. Formant transitions of long vowels in plain and emphatic environments.

_____ aa - - - - - ii _____ uu
 ee _____ oo

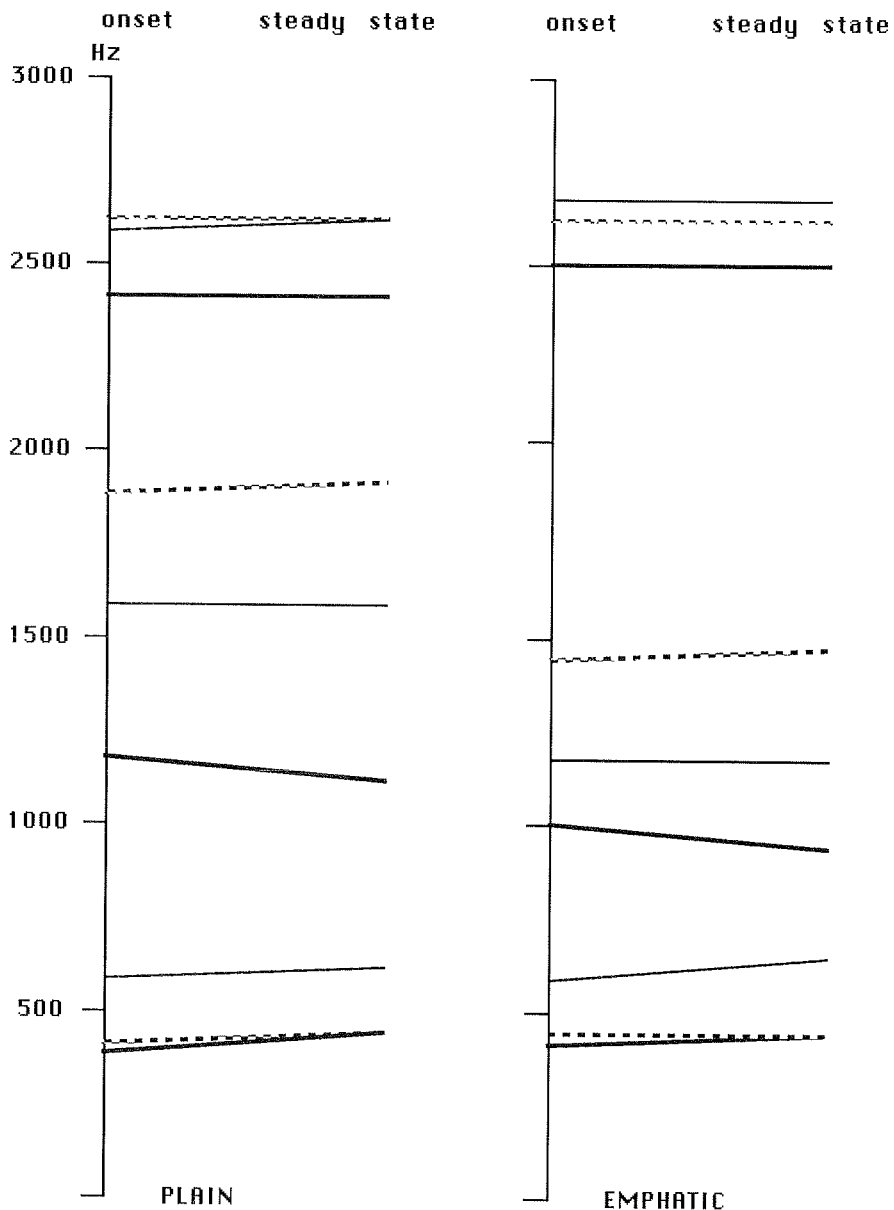

Figure 18. Formant transitions of short vowels in plain and emphatic environments.

———— a - - - - - i u

6.2. Results and discussion.

6.2.1. Shared traits in onset frequency between long and short vowels.

Table 6-A reveals some common traits of formant onsets, which distinguish long as well as short emphatic vowels from plain ones. With two exceptions, all onset frequencies show the same general pattern. The large decrease of F2 in emphatic vowels is always highly significant for long as well as short vowels and is the most conspicuous acoustic property of emphasis. F1 and F3 rise very moderately, except for /uu/ and /oo/, which show a larger increase in F3. Long /oo/ and short /a/ deviate a little from the general pattern. /oo/ has a very small decrease in F1 and /a/ shows no difference at all between onsets in plain and emphatic environments.

6.2.2. Long vowels.

The two sets of long /aa/ behave in an exceptional way compared with the other long vowels, because of the distinct qualities of plain and emphatic /aa/ as can be seen in Table 6-A. The inter-speaker variation for F1 and F2 appears to be very small. Onset F2 of emphatic /aa/ undergoes very large changes in comparison with plain /aa/. Where F2 of plain /aa/ starts at around 1750 Hz, F2 of emphatic /aa/ is very much lowered and starts under 1200 Hz, a difference of nearly 600 Hz at the onset. The center frequencies of the vowels are even more different, (cf. preceding chapter). Where the formant of plain /aa/ is rising from the onset to a steady state at around 1800 Hz, the frequency of emphatic /aa/ drops from the onset by up to 150 Hz and the center frequency is for all informants around 1050 Hz. This steady state frequency is nearly 700 Hz lower than for plain /aa/ on the average.

The onset frequency of F1 is also significantly different between the two sets. The difference is not very large, however, emphatic vowels being 55 Hz higher on the average.

Several speakers have a very high F3 for /aa/ in emphatic environment, between 2800 and 3000 Hz. This is considerably more than the average for all speakers. The mean onset frequency is 2630 Hz for all nine speakers in plain environment. In emphatic environment the mean onset frequency rises by an average of 350 Hz for three speakers to a mean of 2880 Hz, whereas it drops slightly for the remaining six speakers in the same environment. The pattern was found to be consistent in all tokens of long as well as short vowels of the concerned speakers. The difference between plain and emphatic vowels in F3 is not significant, however.

The two sets of long /ee/ differ significantly for both F1 and F2. The changes in F2 for emphatic long /ee/ are not as great as for long /aa/. F2 of plain /ee/ has an onset where the speakers are close

		plain	emphatic	diff. (emph. - plain)
/aa/	F1	495	550	55
	F2	1750	1160	-590
	F3	2630	2665	35
/ee/	F1	350	415	65
	F2	1900	1660	-240
	F3	2640	2675	35
/ii/	F1	300	340	40
	F2	2225	1870	-355
	F3	2945	2665	280
/oo/	F1	420	405	-15
	F2	1320	985	-335
	F3	2360	2630	270
/uu/	F1	355	365	10
	F2	1145	935	-210
	F3	2370	2635	265
/a/	F1	575	575	0
	F2	1595	1170	-425
	F3	2605	2655	50
/i/	F1	415	435	20
	F2	1875	1445	-430
	F3	2615	2595	20
/u/	F1	405	425	20
	F2	1185	990	-195
	F3	2420	2495	75

Table 6-A. Mean onset frequencies of plain and emphatic long and short vowels. Emphatic means are based on the collapsed values of ÇVVC and ÇVVÇ.

together at around 1900 Hz. This frequency drops by slightly less than 250 Hz on the average in emphatic environment. F1 is around 60 Hz higher in emphatic surroundings, whereas F3 shows a very small and nonsignificant rise.

Long /ii/ differs significantly between plain and emphatic surroundings in F1 as well as F2 and F3. The F1 onset is higher for emphatic /ii/, rising about 40 Hz. The F2 onset drops by around 350 Hz on

the average. The F3 onset drops by circa 280 Hz on the average. The difference is significant.

The formant onsets for plain and emphatic long /oo/ show no significant differences in F1 and F3, even if the average F3 onset is higher for emphatic vowels by around 270 Hz. It is highly different in F2, which drops for emphatic vowels by an average of 335 Hz. As in the case of emphatic /aa/, F2 drops from the onset to the center frequency of the vowel, instead of rising as it does for /ee/ and /ii/.

For long /uu/ all three formant onsets are significantly different in emphatic environment. The rise of the emphatic F1 onset is small and of a low significance level as are F3 onsets. The emphatic F2 onset drops, by an average of little more than 200 Hz. F1 and F2 both drop towards the center frequency of the vowel.

6.2.3. Short vowels.

As might be expected the short vowels follow essentially the same pattern as the long ones. Short emphatic /a/ and /i/ both have a large and highly significant drop in the F2 onset when compared to plain /a/ and /i/, whereas the differences in F1 and F3 are small and non-significant for both vowels.

The three speakers, mentioned in the previous section, having a considerably raised F3 in onset in emphatic environment, consistently produce the same pattern for short /a/.

The difference in onset is considerably larger for short /i/ than it is for long /ii/.

For short /u/ the difference in F2 onset is much smaller than for the other short vowels and of a lower significance level.

6.2.4. The phonetic and phonemic status of [e] and [o].

Short /i,a,u/ are undisputedly regarded as phonemes in all phonological analyses of Egyptian Arabic. The treatment of short [e] and [o] differs. They are generally not treated as phonemes in descriptions of the phonological system of the language. In most cases they are not even mentioned (e.g. Woidich 1980:207) or when they are, they are described as allophones of /i/ and /u/ (Birkeland 1952:48). Their phonetic qualities do not seem to have been investigated. Jomier (1964:3) does not make a phonemic analysis, but describes five different short vowels, [i,e,a,o,u]. He does not define very clearly under what circumstances [e] and [o] occur and concludes the description by giving the advice "se laisser guider par l'oreille". Mitchell (1978:9f) reckons with five short vowels, but does not discuss their phonemic status. Abdel-Massih (1975:21) also mentions five vowels, but lists them in the inventory of short vowel phonemes, thus being one of the few to include a series of short mid vowel phonemes. Although the occurrence of short

[e] and [o] may be said to be common in the language it seems difficult to define distributional rules. He also states, however, that the occurrence of short [e] and [o] in contrastive positions is not very common and that it is difficult to discriminate between [i] : [e], and [u] : [o], for non-native speakers.

There are very few minimal pairs where [e] can be said to contrast with [i] and [o] with [u], but Abdel-Massih (op.cit.) gives a couple of minimal pairs to demonstrate the opposition. Words with short [e] and [o] are obtained by morphological processes, adding pronominal suffixes to verbs and nouns with long /ee/ and /oo/ vowels, respectively. By way of this process the long vowel is automatically shortened. For example /betna/, 'our house', from /beet/, 'house' contrasts with /bitna/, 'we spent the night', from /baat/, 'to spend the night', a verb with a short [i] vowel in this particular form of the past tense. In his second example, the same morphological process shortens the long /oo/ of a noun of Turkish origin, /ʔooða/, 'room'. Due to further phonological processes this affixation gives the form /ʔoʔʔi/, 'my room', which is in contrast with /ʔuʔʔi/, 'my cat', from /uʔʔa/, 'cat'.

Short [e] and [o] thus seem to appear in contrastive position only in words where long /ee/ and /oo/ have been shortened in morphological processes. These cases are consequently quite rare.

To find suitable words to investigate the acoustic properties of [e] and [o] and compare them with short [i] and [u], the same procedure as in Abdel-Massih's examples was resorted to, since words forming minimal pairs in other ways were not found. The monosyllabic test words with long /ee/ and /oo/ had personal pronoun suffixes added to them, thus forming disyllabic words where the long vowels are shortened before two following consonants. This is according to the rule mentioned in the Introduction, which says that a long vowel cannot precede two consonants. [e] and [o] were only investigated in plain environment, disregarding the emphatic phonological contexts.

Birkeland (1952) states that it is very difficult to define the quality of /i/ in many cases, particularly in unstressed closed syllables. The sound could often be transcribed with any of the symbols [i] and [e]. The same state prevails concerning [u] and [o]. It would make no difference to pronounce the word for 'mother' as [ʔumm] or [ʔomm]. This investigation does not show, however, that there is any greater variation in these two vowels than in the other vowels.

There is obviously a clear acoustic difference between [i] : [e] and [u] : [o], consisting in highly significant differences in formant onset frequencies. The most important differences are in F2 where [o] has a higher onset frequency than [u] by an average of 100 Hz ($p < 0.01$). Short [e] has a lower onset than [i] by an average of 105 Hz ($p < 0.01$). It is also possible to list at least a limited number of minimal pairs where this difference signifies a differentiation in meaning. The acoustic difference is unusual, however, since it depends on onset frequencies only, and not of center formant frequencies of the vowels. According to their phonetic structure they could rather be analyzed as diphthongs and be

phonetically transcribed [eⁱ] and [o^u]. [eⁱ] has the onset frequency of [e], but reaches the center frequency of [i]. [o^u] has the onset frequency of [o], but drops to the center frequency of [u].

In spite of the fact that [e] is phonetically different from [i], and [o] from [u], it is difficult to accept the conclusion of Abdel-Massih and others that the short mid vowels ought to be analyzed as phonemes, or that only [o] has to, according to Gamal-Eldin. As Birkeland (op.cit.;47) and Drozdik (1973) point out, the reason for this is that [e] does not contrast with [ee], and [o] does not contrast with [oo]. The long vowels occur only in open syllables or before one consonant. On the other hand, the short vowels [e] and [o] are found only as the result of morpho-phonological rules, by which [ee] and [oo] are shortened before consonantal clusters or otherwise occur in unstressed syllables. This process is thus conditioned by syllabic structure and stress patterns and is entirely predictable. Consequently, short [e] is better analyzed as an allophone of /ee/ and short [o] as an allophone of /oo/. This analysis has also been proposed by Wise (1975).

The conclusion must be that short [e] and [o], while distinct from [i] and [u], are not phonemes in Egyptian Arabic, and that the language does not possess a set of short mid vowels in correspondence to the long ones.

This investigation shows, however, that [e] and [o] are phonetically distinct from [i] and [u], showing significantly different transition patterns, as compared to the latter pair. Thus, on the phonetic, but not on the phonemic level, there are five short vowels in Egyptian Arabic.

SIX

6.2.5. Treatment of short vowels in Egyptian dialects.

A development of short mid vowel phonemes in Egyptian Arabic in contrast to Standard Arabic and the western dialects would not be unique or impossible. According to available investigations many dialects in the eastern dialect area have added new short vowel phonemes to the classical three vowel system. This seems to be the fact within Egypt itself. Khalafallah (1969) identifies a linguistic area with subdivisions in the Nile Valley stretching from the south of Cairo to Aswan, a distance of about 900 kilometers, where the inhabitants share many dialectal traits. One of them is said to be the use of five short phonemic vowels.

Omar (1973) investigated a dialect in Upper Egypt in an area which belongs to the northern main subdivision of southern Egyptian dialects in Khalafallah (1969). She lists six long vowel phonemes (op.cit. 28f.), splitting /aa/ in the present investigation into two phonemes: /ææ/ and /aa/. There are also six short vowel phonemes, each one corresponding to a long one. The phonemic status of [e] and [o] is expressly stated in opposition to an interpretation of them as allophones of /i/ and /u/. Despite numerous examples of vowel distribution it is difficult to appraise the phonemic function of the vowel

qualities in the examples given, since they are not presented in minimal pairs or according to the distribution method. The influence of emphasis on vowel quality and the phonological consequences is not discussed.

Gamal-Eldin (1967;11) is of the opinion that not only southern dialects in Egypt has increased the number of short vowel phonemes as compared to the classical system. Without going into details, he suggests an analysis of the short vowels of Egyptian Arabic, understood to be the dialect of Cairo, into a four vowel system. He classifies [e] as a phoneme, but not [o].

The treatment of the short vowels in the dialect based on the speech of Cairo has differed with different investigators and their methods of analysis. The reason is probably the existence of a variety of phonetically different short vowel sounds, which is not uncommon in languages with limited vowel inventories, and the existence of seemingly minimal pairs, which appear to exhibit phonemic opposition. It has been found difficult to formulate distributional rules for the allophones, ("se laisse guider par l'oreille"), at the same time as minimal pairs with phonetic opposition have proved to be rare and appearing in rather restricted contexts.

Spitta-Bey (1880) mixes what nowadays would be divided into phonemic and phonetic analysis, but so far as it is possible to make this division of his treatment of short vowels, he seems to identify five long and three short vowels, which are described in a rather large number of context dependent allophonic variations.

Harrell (1957) identifies five long vowels and three short ones, the same as in this investigation. In addition he reckons with two short epenthetic vowel phonemes, /e/ and /o/, together with a voiceless intercostal syllable pulse, symbolized /-/. The last phoneme seems to be a tentative innovation on which no insistence is made. As regards the phonemic status of /e/ and /o/, it has been refuted by Blanc (1959) in his review of Harrell's book. A possible contrast, set up by Blanc, between for example /ʃuftemi:n/, 'whom did you see', m.s., and /ʃufti mi:n/, 'whom did you see', f.s., does not necessarily have to be analyzed as a phonemic distinction, as the epenthetic vowel /e/ in the first example does not differ from unstressed /i/ in medial position in a word like /muslimi:n/, 'Muslims'.

In a later book by Harrell et al. (1963), short /e/ and /o/ are removed from the presentation of the phoneme inventory, leaving /a,i,u/ as the only short vowel phonemes.

6.2.6. Short vowels in some other Arabic dialects.

A comparison between studies of Egyptian Arabic and other dialects in the eastern dialect area shows that the phonemic analysis of the short vowels often is uncertain and surrounded by guarded arguments. It seems as if the short vowel system is in a flux and that phonemic oppositions are under development and not yet quite estab-

lished. Another explanation of the vagueness might be the weakness in many presentations of the various phonological vowel systems insofar that they seldom go neither into phonetic details nor present examples of minimal pairs where the contrastive function of the phonemes is obvious. As a result the same dialect can be said to have a different number of short vowels, depending on the author.

Many dialects in neighbouring countries seem to have developed more short vowels than the classical three. Card (1983) identifies five short vowel phonemes in her investigation of the Palestinian dialect, but does not go into details. Rice and Said (1960:XX) also recognize five short vowels in the same dialect. None presents minimal pairs.

Cowell (1964:9f.) finds six short vowels in the variety of Syrian Arabic he describes. His aim is a description of the language of educated city-dwelling Syrians, particularly the natives of Damascus. He includes /ə/ in the phonemic inventory in addition to /e/ and /o/. Since dialectal variation can be considerable within a rather restricted area, he underlines that five vowels exist, with the exclusion of [ə], particularly in Lebanon and Palestine, and that its functional autonomy is marginal, even where it exists (op.cit.;13), and that the classical three vowel system is found in some cases. Unfortunately, examples in the form of minimal pairs are missing.

In contrast to Cowell, Grotzfeld (1965) finds only three short vowels, /a,e,o/, in the Syrian dialect, where the symbols /e/ and /o/ seem to capture a development to a more centralized position in the vowel space.

In his grammar of Iraqi Arabic, Erwin (1963:17f.) reckons with a four vowel system, /i,a,o,u/. The development of an /o/ phoneme could be the outcome of a parallel development as compared with Egyptian Arabic where the acoustic differences between [o] and [u] are greater than between [i] and [e].

Palva (1976;14f.) investigated a Bedouin dialect in Jordan and found, not surprisingly, that the phonemic status of the short vowels is problematic. In his transcription he indicates six different vowel qualities, but analyzes the system to have four phonemes.

In an earlier work on Galilean Arabic, Palva (1966) found the classical short vowel system retained, showing the three short vowel phonemes /a,i,u/.

6.2.7. Onset frequency in other Arabic dialects.

Comparable onset data for Lebanese Arabic from Obrecht (1968;24f.) are available for /aa/ and /ii/, pronounced after dental consonants. The F2 onset drop for /aa/ in emphatic environment is 450 Hz, which is less than in Egyptian Arabic. The F2 onset drop for /ii/, 600 Hz, is larger, however.

Vowels in Lebanese Arabic, except /aa/ and /a/ seem to signal emphasis in the formant transitions, while the center frequencies reach

a standard level, which is roughly the same in plain and emphatic context. Egyptian Arabic on the other hand generally displays differences in both onset and center frequencies.

Jiha (1964;123) makes a qualitative evaluation of emphasis in the Lebanese dialect of Bismisīn. He states that its presence is noticeable mainly in /aa/ and /a/ vowels. This is in accord with Obrecht's results, which show that only /aa/ and /a/ are altered throughout in their acoustic structure in emphatic environment and thus should display the contrast more audibly.

Ghazeli (op.cit. 78) lists F2 onset frequencies for short vowels in plain and emphatic environment. His values are pooled data from twelve subjects of seven nationalities. The majority of the speakers came from Algeria, Libya and Tunisia. Thus it is impossible to get an idea of dialectal variation. The tendency is clear, however. The drop in F2 is very large. The onset frequencies in emphatic environment are roughly the same as in Egyptian Arabic, whereas onset frequencies in plain environment are higher. The gap between plain and emphatic onset frequencies are therefore even larger in Ghazeli's investigation than in the present one.

Fre Woldu (1981) investigated formant onset frequencies after plain and emphatic dental stops, in addition to the study of non-spectral properties of the two consonant sets, referred to in chapter 4.3. In the acoustic investigation seven speakers came from Algeria, Morocco and Tunisia and one from Sudan. The results show that F1 rises, as in Egyptian Arabic, but considerably more. The rise is 150 Hz for /i/ and /u/ and 100 Hz for /a/. In Egyptian Arabic F1 rises by more than 50 Hz in only two cases, /aa/ and /ee/.

The F2 drop after emphatic stops is very large for all vowels, as much as 800 Hz for /i/ and 600 Hz for /a/ and /u/. These differences are even larger than what has been measured for Egyptian Arabic, for /i/ and /u/ much more, but the findings are consistent with Ghazeli (op.cit.) who also found larger differences in onset frequencies after emphatic consonants than is the case in Egyptian Arabic.

Fre Woldu also measured F3 in onset. Instead of a slight rise in frequency after emphatic consonants there is a drop by 100 Hz for /u/, 200 Hz for /i/ and a very large one by 800 Hz for /a/. This drop in F3 for all vowels is contrary to Egyptian Arabic where all vowels, long and short, has a higher F3 in emphatic environment, and where some speakers even have a remarkable rise in F3 for /aa/ and /a/.

Judging from the available material on formant frequencies in different Arabic dialects, it seems as if the dialects in Africa make a large difference between plain and emphatic vowels, the dialects in the Maghrib even more so than in Egypt. The differences are far less pronounced in what has been found in investigations of Iraqi and Palestinian Arabic.

Giannini-Pettorino (op.cit. fig 8) show the onset frequencies for short vowels in Iraqi Arabic. Since their object is to show the locus of the converging formants they do not have tables of onset frequencies. It

is evident, however, from the figure that the gap in onset between plain and emphatic vowels is rather large also for Iraqi Arabic.

Al-Ani and El-Dalee (1984) report formant frequencies for another Egyptian dialect. They present data for one speaker from Alexandria. The same general pattern is visible here, but the drop in F2 steady state frequency is much larger than it is for Cairo speakers. It amounts to roughly 400 Hz instead of 145 Hz in this material. The drop for /aa/ is about the same in both dialects and the difference for /uu/ in plain and emphatic environment is also nonsignificant.

6.2.8. The importance of onset frequency and center frequency for emphasis.

As has been shown in the previous section, other investigations of various Arabic dialects show that formant transitions of sometimes drastic ranges occur after emphatic consonants in comparison to transitions after plain consonants. The perceptual importance of these transitions have also been tested (Obrecht 1968). Their function as a major cue for emphasis in the syllable context is well established. Egyptian Arabic is no exception to the general pattern in this regard among its sister dialects, but shows some characteristic variations on the theme. Table 6-B lists changes in frequencies in plain and emphatic environment and gives a picture of the differences in the acoustic structure of the two vowel sets.

It is obvious from this table that the greatest changes in the acoustic structure of vowels affect the formant transitions when going from plain to emphatic environment. The particular quality of vowels in Egyptian Arabic is a combination of onset and center frequencies. Both are lower in this dialect in emphatic surrounding than in other dialects for which data are available.

F2 is without question the most important single cue for emphasis. F1 seems to have an importance for distinguishing back places of articulation. El-Halees (1985) performed perceptual tests to compare the results with the predictions of Stevens and Klatt's (1969) model of relationships between area functions of the vocal tract and formant structures. Arabic has several back places of articulation as can be seen on the consonant chart in the Introduction. El-Halees found that a step-wise rising F1 in the synthesized test words caused the test subjects to make a distinction in a discrete manner between uvular and pharyngeal sounds, connecting the higher F1 with the more back place of articulation. F1 therefore makes a contribution to the emphatic sounds, but does not seem to be immediately related to the feature emphasis.

El-Halees's investigation deals with Jordanian Arabic. It is difficult to decide the importance of F1 in Egyptian Arabic due to the nonsignificant or low level significance in the rise of F1 in emphatic environment as compared with the plain counterpart.

		onset	steady state
/aa/	F1	55	35
	F2	-590	-695
	F3	35	25
/ee/	F1	65	25
	F2	-240	-115
	F3	35	65
/ii/	F1	40	30
	F2	-355	-145
	F3	280	-260
/oo/	F1	-15	-5
	F2	-335	-35
	F3	270	250
/uu/	F1	10	25
	F2	-210	ÇVVC -25
			ÇVVÇ 5
	F3	265	265
/a/	F1	-	15
	F2	-425	-420
	F3	50	45
/i/	F1	20	15
	F2	-430	-430
	F3	20	-15
/u/	F1	20	35
	F2	-195	-165
	F3	75	55

Table 6-B. Differences in onset and center frequencies between plain and emphatic environment.

The importance of F3 in the plain-emphatic distinction is also difficult to assess. Few investigations report data on F3, although existing data indicate the same slight rise as in Egyptian Arabic. The contribution of this formant to the auditory impression is not known, due to the lack of perceptual tests. It is likely that its importance is rather small and negligible in most cases. The rise in F3 frequency is mostly very moderate and often nonsignificant or of a low significance

level. The amplitude of F3 is often very weak for mid and high back vowels as can be seen on spectrograms.

Al-Ani and El-Dalee (1984) indicate that F3 is used as a separate acoustic parameter for distinguishing some phonemes in Arabic. They do not say what phonemes, however, and do not give formant values for F3 or refer to any perceptual tests.

Available tracings of X-ray studies of Egyptian Arabic (Wood 1982) do not make it possible to compare the extent of the secondary back constriction for long and short vowel in emphatic environment during their articulation and the changes that must occur when going from an emphatic consonant to a following vowel. The acoustic results, however, suggest that the secondary constriction connected with an emphatic consonant rapidly decreases during a following vowel, but without disappearing altogether. An indication of this is that all long vowels, except /aa/ get very close to the frequency level of the steady state portion of the plain vowels. The great difference between plain and emphatic vowels are in the onset frequencies whereas the direction the transitions are going towards a target which in most cases differentiates very little between plain and emphatic environments. The differences between plain and emphatic vowels in the center frequency are so small for high and mid vowels that their perceptual importance in many cases can be doubted.

The short vowels, however, have a greater quality difference than the long ones, as is shown by their large differences in center frequencies, in addition to the large differences in onset frequencies. This seems natural considering their comparatively short time of articulation. During a short time span the constriction in the pharynx cannot be expected to decrease to the same degree as is the case with the long vowels which are about twice as long. It is thus not possible for emphatic short vowel to reach or approach the target values for plain short vowels as the emphatic long ones approach the target of the plain counterparts.

6.2.9. Long /aa/ and short /a/.

As was stated in the Introduction Egyptian Arabic is traditionally analyzed as having five long and three short vowels. The low vowels /aa/ and /a/ then both occur as front and back allophones. Next to an emphatic consonant the back allophone [a] always occur. The emphatic consonant conditions the quality of the vowel and the front allophone [æ] can consequently not be found adjacent to a consonant of this class.

If the occurrence of [æ] and [a] had been completely regular and in complementary distribution there would be a clear case of a single /aa/ phoneme and a short counterpart both having front and back allophones occurring in plain and emphatic environments. [a] would then occur only with emphatic consonants and [æ] in all other cases. This is not so, however. There is no obstacle for [a] to occur together with most, if not all other consonants in the language. Ghazeli (1977:133) who

investigated a rather large number of dialects, including Egyptian Arabic, also found that back [a] occurs quite independently of emphatic consonants. The occurrence of [a] in combination with other consonants than the four which traditionally have been classified as emphatics, has led many to suggest that Egyptian Arabic, as well as other dialects, has a number of additional emphatic consonants. According to Abdel-Massih (1975;6) there are two other emphatic consonants, /ɣ/ and /r/ in addition to plain /l/ and /r/. /b̥/ has also been suggested as an emphatic phoneme in Egyptian Arabic and Ghazeli (op.cit.;135) lists /b, m, l, f, g, n, k/ as having been proposed to have emphatic phonemic counterparts, although he does not mention if this applies to all dialects he investigated or only some of them.

It is obvious that long /aa/ and short /a/ are a special case in the phonemic system of Egyptian Arabic. The ill-defined distribution of the allophones of /aa, a/ and the remarkably large differences in quality in front and back position have caused much confusion in defining their status, as well as the number of emphatic consonants.

The occurrence of a back [a] has according to Ghazeli (op.cit.;134) led to the conclusion that the adjacent consonant always must be emphatic and that Arabic dialects show an increasing number of emphatic consonants. This is because it is generally assumed that Arabic has one low vowel phoneme only, the back allophone of which occur exclusively adjacent to emphatic consonants. Ghazeli (op.cit.) suggests, however, that the backing of certain or all consonants do not necessarily imply that they are emphatic. The articulatory and acoustic back properties which have been found in these consonants might just as well depend on the fact that they are next to a back vowel phoneme. It is not self-evident that Egyptian Arabic and several other dialects possess five long and three short vowel phonemes. There are strong indications of a phoneme split which has affected the low vowel, resulting in one front and one back low vowel.

Ghazeli points out a lot of inconveniences in attributing emphatic status to a growing number of consonants. He underlines that the emphatic consonants which he prefers to call pharyngealized, have common traits in the articulatory and acoustic fields which they share as a class. All of them affect adjacent segments in a consistent way. They can further occur in any vocalic environment without loss of their phonemic status. None of these characteristics are shared by other so called emphatic or pharyngealized consonants. They have been classified as such because they freely occur next to back [a] without the presence of /t̥, d̥, s̥, z̥/ in the word exerting their backing influence.

That this is the case for Egyptian Arabic support Ghazeli's analysis and makes it applicable also for this dialect. One well known example of a minimal pair where /b/ is supposed to contrast with /b̥/ is [baaba], 'dad' or 'Pope' and [bææb], 'door'. Similar pairs with other consonants can also be found. This allegedly emphatic /b̥/ and other allegedly emphatic consonants differ from /t̥, d̥, s̥, z̥/, however, in that the former never remain back with any other vowel except [a], whereas

the latter remain pharyngealized wherever they are found. It is impossible to find sequences of [ḥi, ḥi, ḥu, ḥu] etc., whereas words containing sequences of any vowel together with any of the emphatic /ṭ, ḍ, ṣ, ḏ/ easily are found. No minimal pairs or near minimal pairs containing other vowels than back [a] seem to have been accounted for in any investigation of Arabic dialects and certainly not for Egyptian Arabic.

The phonetic data in obtained in this investigation of Egyptian Arabic also support Ghazeli's analysis of a split of the low vowel in two phonemes in many dialects. The large difference in quality between the front and back low vowels belong to these data. As has been shown in the preceding chapters on vowel quality and formant transitions the large differences in both onset and center frequencies between front and back [æ] and [a] does not occur for the other long and short vowels in plain and emphatic environment. This can be interpreted in the light of the fact that acoustic analyses of vowel systems in different languages show a strong tendency for vowels to be distributed in the acoustic space in a way that facilitates maximal perceptual contrast (Liljencrants, Lindblom 1972, Bannert, Gårding, Wood 1979). It is

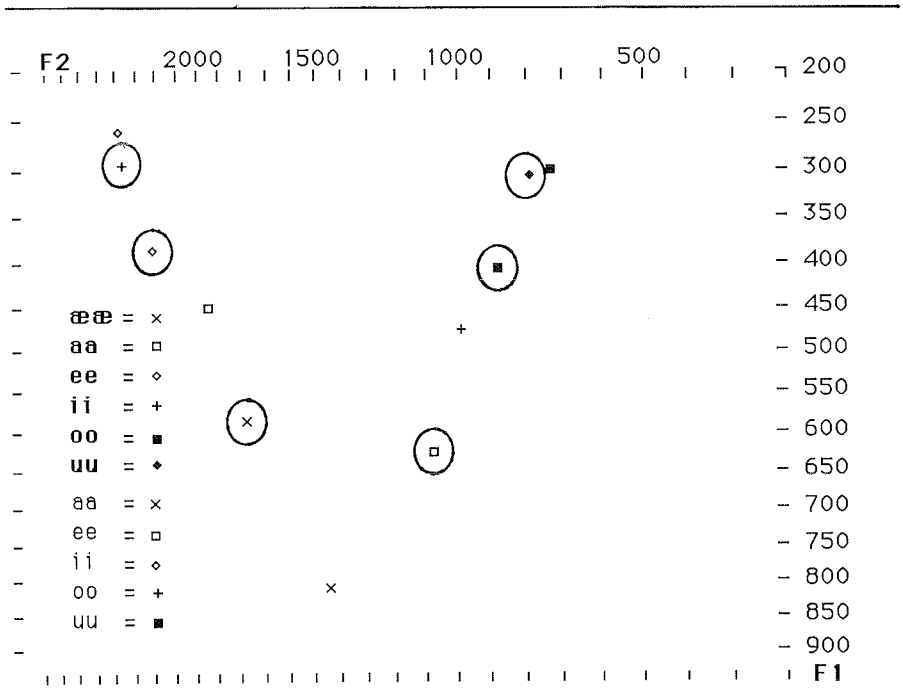

Figure 19. Comparison between Egyptian Arabic and Czech long vowels. Egyptian vowels within circles.

unlikely to find a language where the vowels are more or less grouped together in a given section on a formant chart. Czech is a typical example of a symmetric distribution of the vowels in the acoustic space. It has five long vowel /aa, ee, ii, oo, uu/, as Egyptian Arabic and also five corresponding short vowels. Figure 19 shows the Egyptian Arabic and Czech long vowels, the Arabic low vowel represented by both front [æ] and back [a]. The Czech data are from Wodarz (1970).

A comparison between the two languages shows that the Egyptian vowels are not as regularly spaced as the Czech five vowels, if there is only one low vowel in Egyptian Arabic. In that case it is found to be very front, being half way between the Czech /aa/ and /ee/. This is due to its formant structure, having a lower F1 and a higher F2 than Czech /aa/. On the other hand it has a very back allophone which can only occur next to emphatic consonants. /ii/ and /ee/ are much closer to each other as are /uu/ and /oo/ in Egyptian Arabic as compared to Czech.

If Egyptian Arabic has only five long vowels the language displays a rather asymmetric distribution of its vowels in the acoustic space. It has three front vowels, high, mid and low and two back vowels, mid and high, with a large empty area where a low back vowel could be expected. Not all languages with a five vowel system can be supposed to have a near perfect symmetry as Czech in its vowel space, but the fronting of the /aa/ in Egyptian Arabic is unusually large if it is the only vowel.

There might be historical reasons for the large differences between a front and back low vowel. Earlier stages of Arabic probably had a central low vowel (Ghazeli, op.cit.;141). Tribal dialects in the Arabian peninsula, Jordan and Iraq still have such a vowel, occurring in context-free environments and further back next to emphatic consonants. From Egypt and westwards we find the fronted /aa/ vowel, varying in quality between [æ] and [ɛ]. The polarization between the low vowel qualities is quite understandable as a means of obtaining maximal perceptual contrast between the vowels in the acoustic space. Supposing that the back [a] in figure 19 is an independent phoneme and not an allophone in emphatic environment, Egyptian Arabic has a symmetric six vowel system, based on maximal perceptual contrast with the vowels at roughly equal distances from each other.

As has been shown in the preceding chapters /aa/ has an acoustic structure that sets it apart from the other long vowels. All long vowels except /aa/ have center frequencies in emphatic surroundings that approach the center frequencies of plain vowels. Long /aa/ is the only vowel where the gap in the center frequency between plain and emphatic environment is even larger than the difference in onset frequency. This acoustic structure of back [a] is maintained also together with other consonants than the four emphatics.

For the other long vowels the coarticulatory effects of adjacent emphatic consonants diminish during the articulation of the vowel. The acoustic structure of the other vowels shows that their comparatively

small differences in plain and emphatic environment (for /oo/ it is even nonsignificant) are best regarded as allophonic variation. Obrecht's (1968;16) experiments with synthetic speech also support this view. By manipulating formant transitions he found that it was possible to go from formant values of plain high, front and back vowels and obtain vowel qualities which were perceived as emphatic by the listeners. This proved quite impossible for /aa/. A low front vowel used as a starting point for manipulated formant transitions indicating an increasing backing typical of emphatic environments was rejected as was a back vowel with transitions indicating fronting. All attempts to produce an acceptable vowel sound in this way were rejected by the listeners.

The phonetic data obtained in this investigation thus support the phonemic analysis proposed by Ghazeli for several dialects. Also Egyptian Arabic seems to have six long vowels, of which there are two low vowels, front and back with short counterparts.

7. MODELLING OF THE VOCAL TRACT

As has been shown in the preceding chapters, the emphatic vowels differ from the plain ones in a combination of different onset and center frequencies, which gives them a characteristic acoustic structure. The typical acoustic structure of emphatic vowels has been shown to consist of a slightly raised F1, a greatly lowered F2 and a slightly raised F3. These shifts in frequency can be found in varying degrees, either in the onset or the center frequency, or in both, as is most obviously the case with /aa/.

The question is what articulatory gesture or combination of gestures could have produced these acoustic results. One way of answering this question is to record utterances on an X-ray film. Experiments of this kind are difficult to perform for several reasons. Nonetheless, data from X-ray investigations with the specific aim of studying the articulatory correlates of emphasis exist for some dialects. Available data from Egyptian speakers are limited. Wood (1982) investigated vowel articulations and includes tracings of tongue profiles for plain and emphatic vowels, pronounced by a speaker from Cairo. Since the velum and rear pharyngeal wall are not traced, it is impossible to see the exact place of tongue retraction during emphatic vowels.

Al-Ani and El-Dalee (1984) have X-ray tracings in their investigation, but do not say in the section Methods whether they come from the same speaker from Alexandria who also furnished the acoustic data, or from some other informant.

On the other hand, the previous chapters on vowel quality and formant transitions have demonstrated the acoustic similarities of the feature emphasis in the compared dialects. Although they vary in degree it is likely that the articulatory gestures are very much the same. The published data from X-ray investigations show striking similarities in the essential articulatory traits, although they represent the geographical end points in the Arabic linguistic spectrum. Egyptian Arabic is probably not an exception and it is presumably safe to suppose that the articulation of emphatic sounds does not differ from other dialects except in details.

X-ray studies of the articulation of emphatic sounds were made by Marçais (1948) for the Algerian dialect of Djidjelli, Ali-Daniloff (1972) for Iraqi Arabic, Ghazeli (1977) for Tunisian Arabic, Giannini-Pettorino (1982) for Iraqi Arabic, Wood (1982) for Egyptian (Cairo) Arabic and Al-Ani and El-Dalee (1984) for Egyptian (Alexandria?) Arabic.

In this chapter the results obtained by X-ray methods will be compared with a model of the vocal tract. Acoustic data from the present investigation will be compared with calculated data of the model. Measured and calculated data will be compared with X-ray tracings to give as a complete a picture as possible of the articulation of emphatic sounds in Arabic. It will also help to clarify the question whether the same articulatory gesture is involved in emphasis over a



F1	F2	F3
616	1660	2700
638	1640	2680
649	1620	2660
649	1610	2640
660	1590	2630
671	1570	2620
682	1540	2620
693	1520	2590
704	1510	2590
704	1470	2570
715	1440	2540
726	1380	2540
726	1360	2520
726	1310	2530
715	1220	2500
671	1110	2500
649	1070	2480

Figure 20. Long /aa/ with calculated formant values for increasing pharyngeal constriction.

whole range of different vernaculars or whether this feature could be produced by different articulatory means. In particular this part of the study aimed at a consideration of the acoustic consequences of both a velar and pharyngeal constriction as the place of secondary point of articulation of emphatic sounds, due to the various suggestions as to the location of it in the literature.

7.1. Procedure.

To investigate the relationship between formants and vocal tract shape a model of the tract described by Ladefoged (1985) was used.

The model is designed to allow for linguistic significant movements of the articulators. The vocal tract is thus drawn with a fixed



Figure 21. Long /aa/ with calculated formant values for increasing velar constriction.

part of the roof of the mouth and the back wall of the pharynx, and with movable parts of the lips, tongue, jaw and larynx. The parameters used for manipulation of the vocal tract shape are jaw opening, lip height, lip protrusion, front raising, back raising, the latter two specifying the tongue shape.

In addition to these parameters there are two experimental parameters included in the model, namely "velarization" and "pharyngealization". These latter parameters specify deviations of parts of the tongue. Velarization permits manipulating the vocal tract shape to get an increased constriction in the velar region. Pharyngealization in the same way permits an increased constriction in the lower pharynx around the epiglottis. If, for example, the pharyngealization parameter is given a value of five to a given position of the tongue, five millimeters of additional tongue retraction is added in the pharynx.

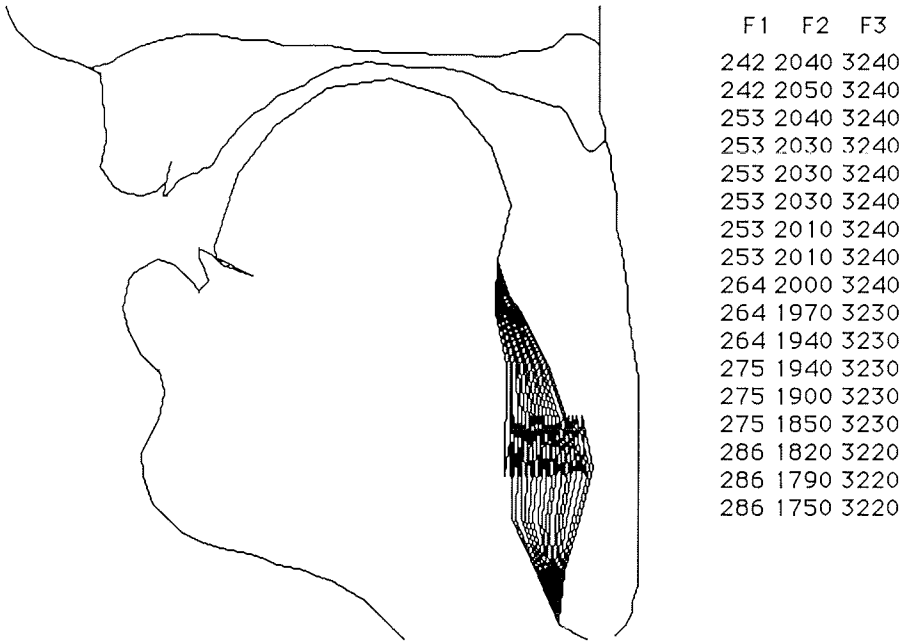
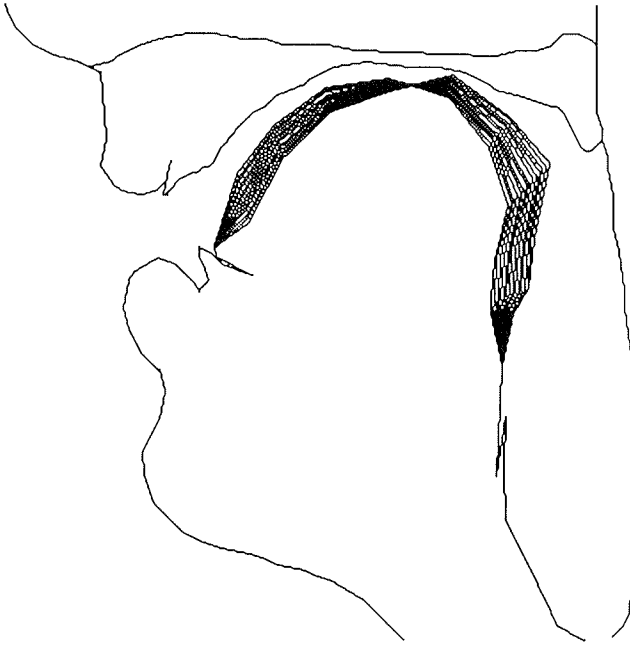

Figure 22. Long /ii/ with calculated formant values for increasing pharyngeal constriction.

Mean formant frequencies of F1, F2 and F3 of each of the long plain vowels /ii, uu, aa/ were used as input to a program that converts vocal tract shapes to formant frequencies, using a variant of an algorithm by Liljencrants and Fant (1975). The five basic parameters of the movable articulators were manipulated to produce several vocal tract shapes for each vowel, and the corresponding formant frequencies were calculated. The vocal tract shape with the set of calculated frequencies that best matched the measured formant frequencies was then used to test the additional parameters of velarization and pharyngealization for each vowel. To these parameters increasing values were added, 1 millimeter at a time. The number of added constrictions for these parameters, shown in the figures 19-24, are the maximum the model would accept, i.e. formant values for additional constrictions could not be calculated by the model.



F1	F2	F3
242	2050	3250
264	2070	3170
264	2110	3100
275	2120	3010
286	2150	2930
286	2140	2930
297	2180	2770
297	2190	2730
297	2220	2690
275	2240	2580
275	2250	2520
286	2250	2510
231	2240	2400
231	2220	2400

Figure 23. Long /ii/ with calculated formant values for increasing velar constriction.

The directions of change of formant values were then drawn as shown in the figures 25-28 on charts of F1-F2 and F1-F3 for both measured and calculated frequencies. For the calculated frequencies directions of change are indicated for both velar and pharyngeal constrictions between input values and the values of maximum constriction, as well as the intermediate trajectories of change, indicated by dotted lines.

7.2. Results.

Figure 25 shows the directions of change of F1-F2 from plain to emphatic environment of the long vowels /ii/, /aa/ and /uu/ for measured and calculated data. The latter have been calculated for both velar and pharyngeal constrictions. Lines have been drawn from the center of the ellipses, based on measured data, which encompass long plain vowels to the center of the ellipses encompassing emphatic ones,

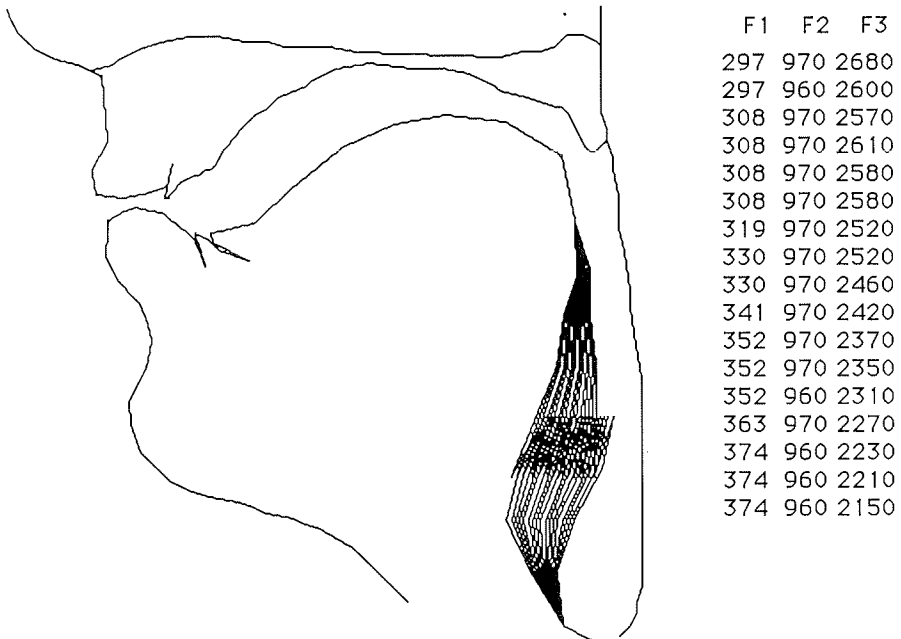
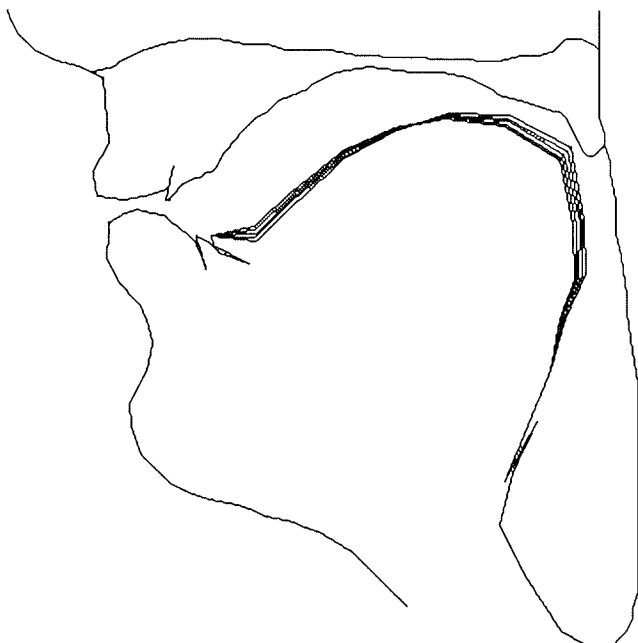

Figure 24. Long /uu/ with calculated formant values for increasing pharyngeal constriction.

also displaying measured data. In the same way lines have been drawn from plain to emphatic vowels, based on calculated values, showing the results of velar and pharyngeal constrictions. The dotted curved lines beside the lines for calculated data indicate the intermediate formant values at increasingly narrowing constrictions.

7.2.1. Results for F1-F2.

A comparison between the directions of change from plain to emphatic environment as based on the measured data and those calculated by the model shows a very good correspondence between the measured data and the calculated data derived from the simulation of the model of a pharyngeal constriction for the vowels /ii/ and /aa/. Calculated data for a velar constriction do not fit measured data for F1-F2 of these vowels at all.



F1	F2	F3
286	970	2690
286	920	2760
286	890	2780
275	830	2830
264	750	2870

Figure 25. Long /uu/ with calculated formant values for increasing velar constriction.

The interpretation of the results for /uu/ is a bit more complicated, depending on the fact that this vowel has two significantly different allophones in the two emphatic syllable structures. In contrast to /ii/ and /aa/, it is therefore not possible to collapse data into one single ellipse for emphatic /uu/. The allophonic variations have to be illustrated by three ellipses, one for plain /uu/ and two for the emphatic surroundings, since the directions of change from plain environment of the latter two differ from each other.

/uu/ in ÇVVC syllables conforms very well with the pattern of /ii/ and /aa/ in emphatic environment and shows all the expected characteristics for emphasis caused by a pharyngeal constriction with a slightly rising F1, lowered F2 (t-value just under significance level) and a rising F3. It does not fit perfectly with the predictions of the model, however, which suggests an unchanged F2 for emphatic /uu/, but since the rising falls short of being significant the deviation from the predictions of the model must be considered to be fairly unimportant.

/uu/ in ÇVVÇ syllables on the other hand fit altogether with model data. F2 of calculated data does not show any sign of the usual

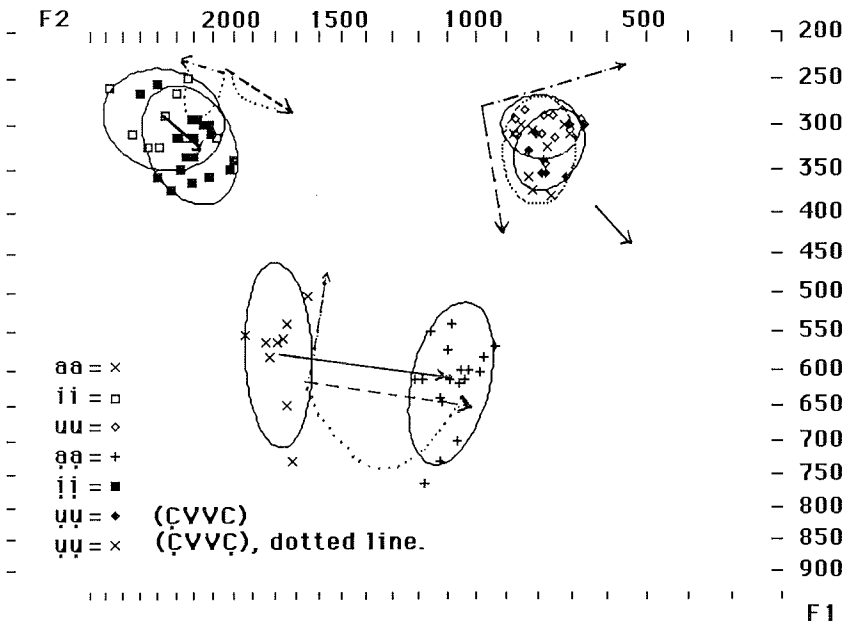

Figure 26. Formant chart of F1-F2 for /aa, ij, uu/ with trajectories showing direction of change in formant values from plain to emphatic environment.

- measured data
- - - - - calculated data for pharyngeal constriction
- · - · - · - calculated data for velar constriction
- intermediate formant values

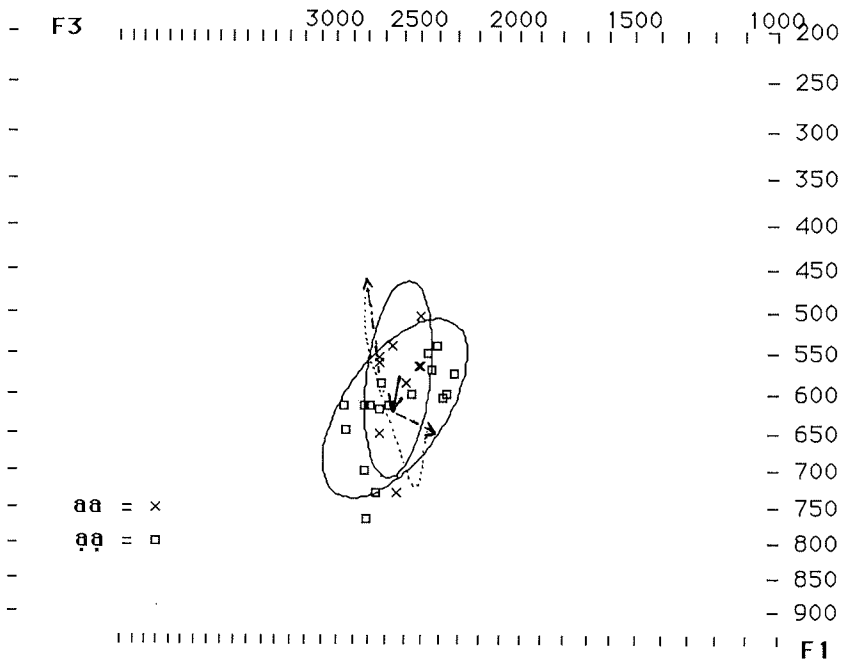

Figure 27. Formant chart of F1-F3 for /aa/ with trajectories showing direction of change in formant values from plain to emphatic environment.

- measured data
- - - - - calculated data for pharyngeal constriction
- · - · - · - calculated data for velar constriction
- intermediate formant values

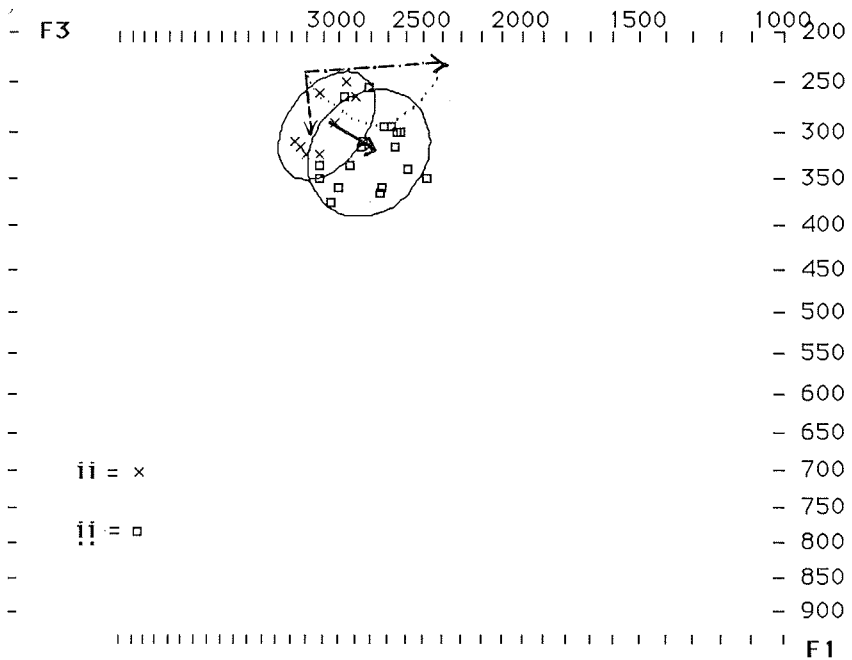

Figure 28. Formant chart of F1-F3 for /ii/ with trajectories showing direction of change in formant values from plain to emphatic environment.

- measured data
- - - - - calculated data for pharyngeal constriction
- · - · - · - calculated data for velar constriction
- intermediate formant values

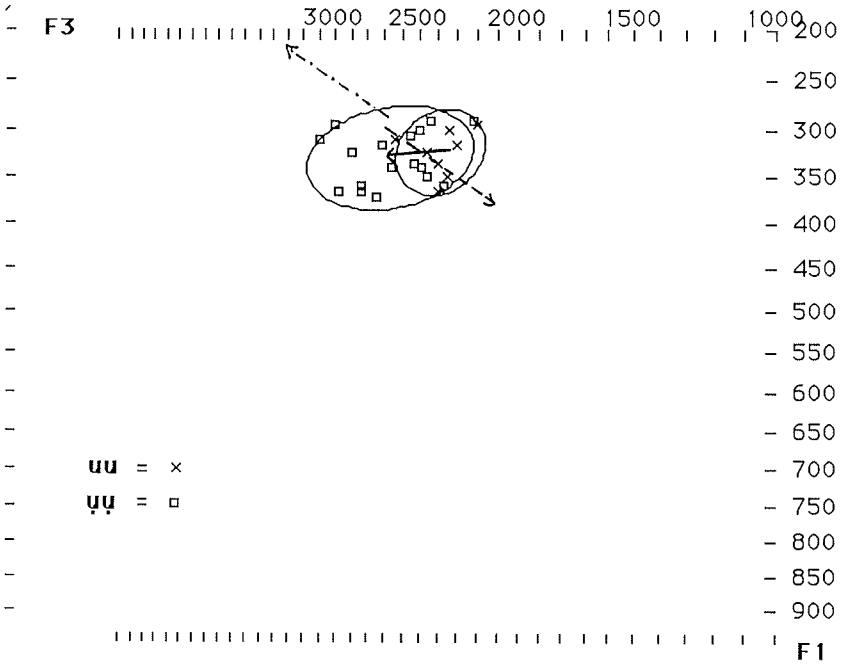

Figure 29. Formant chart of F1-F3 for /uu/ with trajectories showing direction of change in formant values from plain to emphatic environment.

- measured data
- - - - - calculated data for pharyngeal constriction
- · - · - · - calculated data for velar constriction
- intermediate values

/uu/ in ÇVVC syllables on the other hand fit altogether with model data. F2 of calculated data does not show any sign of the usual falling and is not significantly different from measured data, whereas F1 and F3 show the same movements as /uu/ in ÇVVC syllables.

7.2.2. Results for F3.

A comparison between measured and calculated data for F3 on figures 26-28 shows that the fit is somewhat less striking than for the lower formants, with no lines indicating change of direction running parallel to each other, but the divergence shows different degrees depending on the vowel. Long /ii/ shows a rather good fit between measured data and calculated data for a pharyngeal constriction, both having a rising F1 and falling F3, where a calculated velar constriction has a falling F1, thus contradicting measured data. Even if the fall of F3 of the calculated pharyngeal constriction is small, it can be stated that the model has predicted formant values for a pharyngeal constriction for all formants which have proved consistent with measured data.

Long /aa/ also shows a fairly good agreement between measured data and calculated data of a pharyngeal constriction, particularly if one follows the dotted line indicating intermediate calculated formant values until F1-F3 start falling. If the turning point is taken as the most extreme constriction in the pharynx, and the end point of formant changes, with the exclusion of the last three suggested lines of constriction, the fit is quite good and would fit F2 very well too. Thus, even for /aa/ the model data of a pharyngeal constriction are consistent with measured data for all three formants.

On the other hand, /uu/ does not show a good agreement between measured data and calculated data for any constriction. If anything, calculated data seem to be in line with a velar constriction. Two facts make it impossible to draw definite conclusions from available data however. Firstly, as is well known, F3 is weak in high, back vowels and often fails to show up on spectrograms altogether. This has also been the fact in this investigation, and F3 is thus represented by fewer informants than any other vowel. Secondly the model failed to yield a F3 formant frequency low enough to correspond well to measured data despite persistent attempts to manipulate the parameters. It is roughly 300 Hz higher than the average for the informants. If it had been possible to start from lower model data of F3 the fit might have proved to be better than is the case. Anyway it is probably not very important to give a decisive answer to this point since the perceptual importance of F3 for this vowel most likely is very small. A third reason for the less than perfect fit between measured data and model data, particularly for /uu/, is that the place of constriction in the pharynx of the model is lower than it is on tracings of X-ray pictures as will be seen below.

7.3. Comparison with X-ray data.

X-ray data from the dialects mentioned in the beginning of this chapter all show remarkable similarities in the articulation of emphatic sounds. All tracings of X-ray pictures show that the dorsum and root of the tongue are the most important articulators, assuming a characteristic shape. The root of the tongue moves backwards the posterior wall of the upper pharynx at the same time as the anterior part of the tongue has a depressed position, showing a concave profile. In this way a cavity in front of the pharyngeal constriction is formed. The retraction of the root of the tongue also seems to cause a certain retraction of the apex of the tongue. The retraction is clearly pharyngeal, not velar.

Several investigators have tried to assess the role of the pharyngeal wall which could be supposed to play an active part in the articulation of emphatic sounds. Marçais (1948) and Ali, Daniloff (1972) found no signs of any contraction in the pharynx. The rear wall had the same position during plain as well as during emphatic sounds.

Ali and Daniloff (op.cit.) found a considerably lesser degree of tongue retraction for vowels than for consonants on X-ray films. The decreasing degree of pharyngeal constriction during vowel production has been shown in Egyptian Arabic by the direction of formant transitions, going towards a target which is close to or identical with the target of plain vowels.

A comparison between measured formant values for Egyptian Arabic, calculated formant data for velar and pharyngeal constrictions obtained from a model of the vocal tract and data from X-ray investigations, show that the articulatory gesture employed to produce emphatic sounds is a pharyngeal constriction by the root of the tongue in addition to the primary dental/alveolar place of articulation. The term velarization as a description of the production of these sounds is obviously misleading, but even pharyngealization can be said to give a wrong idea about their pronunciation. As far as the pharynx is concerned it does not play an active part as an articulator. It is the tongue which by a backing movement causes the constriction, thus giving the vocal tract the shape which has the acoustic properties associated with emphatic sounds in Arabic.

8. DURATION.

A shared phonological property between many languages of the world is the use of the quantity feature. Its phonetic correlate is generally considered to be a pattern of contrastive duration of segments. These length differences are independently controllable aspects of the speech event as described by Chomsky and Halle (1968:297) and not connected with other causes, such as speech rate, stress or interaction with adjacent consonants. Several investigations, however, have shown that quantity often has more correlates than length distinctions only (Malmberg 1944, Durand 1946). Swedish is for example a well known case where vowel length and vowel quality are closely related. English and German also display the same characteristic connexion between length and quality. In other languages, as Czech and Finnish, this correlation is much less prominent.

The investigation of duration in Egyptian Arabic aimed at giving an answer to the problems indicated above, as well as to a number of other specific questions, some related to emphasis. What are the relations between long and short vowels? Are there any durational differences between plain and emphatic vowels? It is not impossible to expect this. Several hypotheses could be formulated as tentative explanations to such a difference. As is evident on the formant charts in chapter 5 on vowel quality, plain vowels are in several cases more peripheral than emphatic ones. Plain vowels could then be supposed to be of longer duration because of a longer way to their acoustic targets. An opposite assumption would also be possible. Emphatic vowels might be longer than plain ones because of their greater articulatory complexity. Obrecht (1968) found that the time for formant transitions in Arabic to reach a steady state exceeded the time needed in English by 20 milliseconds to secure a correct identification of a preceding consonant. He suggests that the longer time span for formant transitions in Arabic is necessary due to the larger number of oppositions among the stops and a more complex articulation for the emphatics. Thus there are two alternatives. Either the duration of the vowel is prolonged, resulting in a significant difference between plain and emphatic vowels, or is the last part of the vowel articulated with greater speed to level out the differences.

Further, if there are durational differences between plain and emphatic vowels, are they large enough to be considered as a possible differentiating factor? Would it then be worthwhile to go on testing differences in length as a perceptual cue for emphasis?

Are there durational relations between vowels, which can be considered to be connected with intrinsic length, as has been found in many other languages. If so, do these then have the same patterns in Egyptian Arabic as well? Does Egyptian Arabic show, as many other languages do (Lehiste 1970), a compensatory relationship between vowels and voicing in postvocalic consonants? What is the durational relationship between long and short intervocalic stops?

8.1. Procedure.

Productions from six speakers were used for measurements of vowel duration. The test words were divided in two groups. Details are given below in the presentation of each group. The data consist of the five long and the three short vowels whose durations were measured in milliseconds from oscillograms of the first, stressed syllable in disyllabic words, preceded by /f/, /s/ or /ʃ/ and followed by /t/ and /d/. The opposition plain-emphatic was investigated in monosyllabic words. The oscillograms were produced at a speed of 250 mm/second to get as detailed information as possible.

As mentioned in the Introduction, Egyptian Arabic has the following five types of syllables: CV, CVC, CVV, CVVC, CVCC. The last two can only occur in word final position, monosyllabic words included. CV and CVC have an extremely limited occurrence as monosyllables and are found mostly as prepositions and pronominal suffixes, few in number and phonologically and phonetically unsuitable for this investigation.

Long vowels in open and closed syllables cannot be compared because of phonotactic restrictions. CVV does not occur in monosyllabic words and cannot be compared with CVVC, which does. CVVCC syllables do not occur as monosyllables, not even as syllables in polysyllabic words, and cannot be compared with CVVC words. Therefore only long vowels in open syllables have been measured and compared with short vowels.

The two short syllables, open CV and closed CVC, can be compared in disyllabic words and are represented in words of this structure in the material together with long, open CVV, also in disyllabic words.

The limited number of syllable types occurring in Egyptian Arabic, restrictions on their appearance as monosyllabics and their combination into polysyllabics, and the desire to have stress on the investigated syllable in all cases, have determined the choice of the following sets of words as the most suitable for investigating duration.

The first set has been used in order to see whether there is a possible durational difference between plain and emphatic vowels. It has been recorded by eight speakers. Long and short vowels, except /ee/ and /oo/, which were difficult to find in suitable minimal pairs, were measured separately in plain and emphatic environments in monosyllabic words of the syllable structures CVVC and CVCC, forming the following minimal pairs:

saad	'to govern'	ṣaad	'to hunt'
siit	artificial word	ṣiit	'reputation'
suud	'black'	ṣuud	artificial word
sadd	'to close'	ṣadd	'to prevent'
sitt	'lady'	ṣitt	artificial word
sudd	'close!'	ṣudd	'prevent!'

The second set has been used for investigating all other aspects of duration and consists of the following words:

faatu	'they passed'	fita	'winter'
saadu	'they governed'	sidi	artificial word
fattu	'they cut'	fuuṭa	'towel'
saddu	'they closed'	suudu	'govern!'
fata	'to give a legal decision'	futtu	'jump!'
sada	'warp'	suddu	'prevent!'
ṣiiti	'my reputation'	futa	artificial word
siidi	'my lord'	suda	artificial word
ṣeeda	'prey'	sooda	'black'

Durations of long and short vowels and of intervocalic long and short stops were also measured. The duration of voiceless stops was considered to be the occlusion plus the aspiration. The wave-form often shows a few milliseconds of what appears to be pre-aspiration before the complete closure of voiceless consonants following a vowel. This short interval before the occlusion of the consonant has been regarded as part of the vowel. The wave-form of voiced stops presented no problems in defining the boundary between the vowel and the occlusion of the stop. Thus the duration of voiced stops is the occlusion. Mean values for the three tokens of each vowel were calculated in each context for each speaker as well as mean values of the duration of intervocalic consonants in the same contexts.

Long /uu/ preceding the voiceless stop is measured before emphatic /t̤/, which unfortunately does not make the environment exactly comparable to that of the other vowels.

The data are listed in Table 3:1-20.

Paired t-tests were used to determine the statistical significance of durational differences between vowels in the syllable structures mentioned above.

8.2. Results and discussion.

8.2.1. Duration of plain versus emphatic vowels.

Vowel durations were first measured separately in five tokens in plain and emphatic surroundings to look for possible differences in length. Paired t-tests show that vowel duration is not significantly different between plain and emphatic long vowels, nor between plain and emphatic short vowels in these environments. The results are summarized in the following table:

	duration (ms)		t-value	significance	df
	plain	emphatic			
/aa/	171	164	1.898	n.s.	7
/ii/	147	140	0.753	n.s.	7
/uu/	159	157	1.177	n.s.	7
/a/	95	95	0.000	n.s.	7
/i/	73	80	-2.206	n.s.	5
/u/	85	80	1.971	n.s.	7

Table 8-A. Mean duration of long and short plain and emphatic vowels in monosyllabic words.

As the results show, there is a slight tendency for plain vowels to be longer than emphatic ones. This is most clearly seen in the long vowels. As the paired t-tests show the difference is nonsignificant, however. Differences in duration can consequently not be considered to be a differentiating factor for emphasis and it is therefore not necessary to treat vowels as belonging to two different groups in the measurement of duration, depending on the presence or absence of emphasis. As a consequence no perceptual tests, varying this factor, were performed.

8.2.2. Long and short vowels.

Durational differences between long and short vowels vary within rather wide limits in the languages of the world (Lehiste 1970). It can be supposed that these variations in many cases reflect the role of duration in different phonemic systems. The importance of duration as a purely temporal feature can be more or less pronounced, since it can be combined with other features in quite complicated relations. Vowel length can for example be related to different vowel qualities. This will be treated in section 8.2.5. on intrinsic length. It can also be correlated with the length of the following consonants according to regular patterns (Lehiste 1970;20f). In English, phonemically short vowels are quite frequently phonetically longer than phonemically long ones (Wiik 1965;113), and accordingly other perceptual cues than length have to be used to distinguish between them. It is also possible, on the other hand, that the temporal factor alone carries the information in languages where differences in duration do not influence vowel quality in any noticeable degree. There are also languages where listeners do not pay attention to quality differences, but make the phonemic length distinction on the basis of the temporal factor alone, as in Finnish (Lehtonen 1970;87).

The mean durations of Egyptian Arabic vowels and intervocalic dental consonants in the respective syllables are plotted in Figure 26

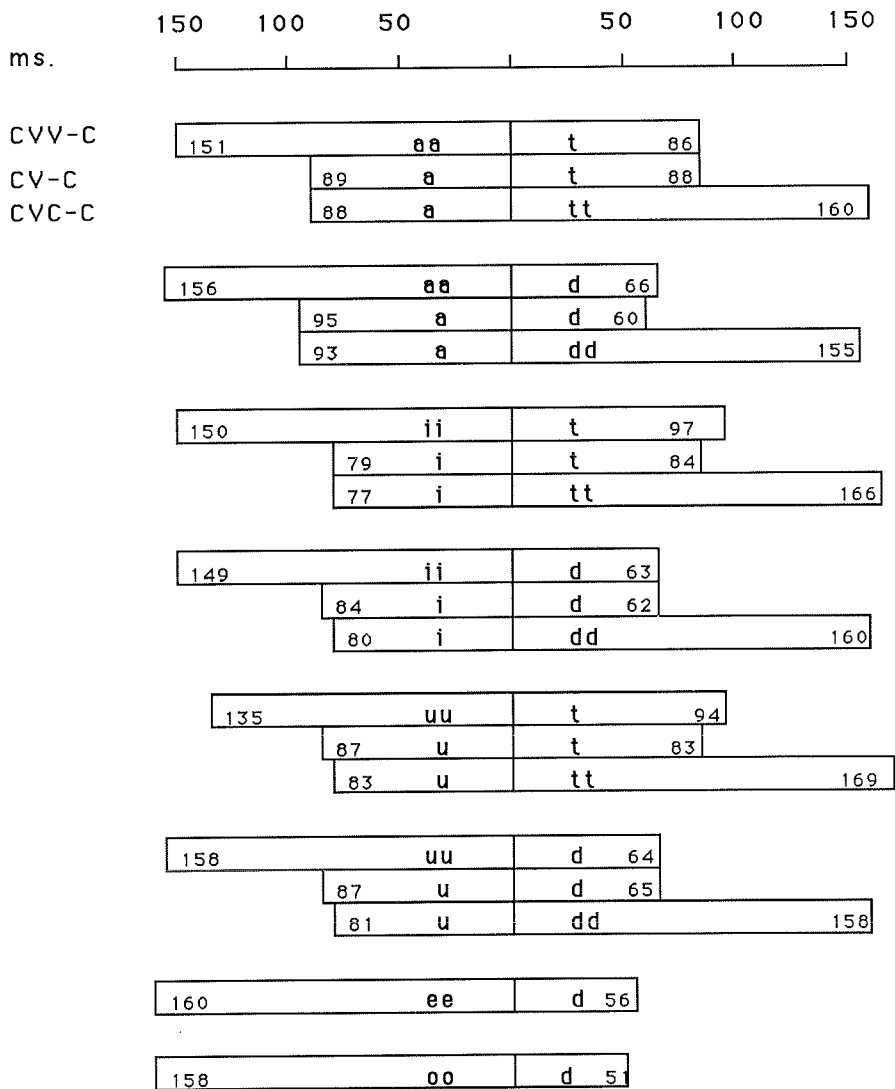

Figure 30. Bar-graphs of mean vowel and intervocalic consonant duration of six speakers

Mean values indicated within bars

and are also listed in Table 3:1-20. The mean values of vowel duration and the V/VV ratio in percent are summarized in the following table:

Duration of long and short vowels (ms)		
	1. preceding /t/	2. preceding /d/
/aa/	151	156
/ii/	150	149
/uu/	135	158
/ee/	-	160
/oo/	-	158
/a/	89	94
/i/	78	82
/u/	85	84

The V/VV ratio expressed as percentage:

	1. preceding /t/	2. preceding /d/	3. collapsed values for both environments
a/aa	59%	60%	60%
i/ii	52%	55%	53%
u/uu	63%	53%	58%

Mean for all long vowels: 152 milliseconds.

Mean for all short vowels: 85 milliseconds.

V/VV ratio of all vowels: 56% or 1:1.8

Table 8-B. Mean duration of long and short vowels in disyllabic words. V/VV ratio in percent.

8.2.3. Quantity in Egyptian Arabic and other languages.

It can be seen that Egyptian Arabic makes a clear durational distinction between the two vowel lengths, long and short. The difference between long and short vowels is highly significant, and rather large. The durations of short vowels are between 52 % and 63% of the long ones. The results show further that the occurrence of a short vowel in an open or a closed syllable does not have any influence on its length. The small differences are not significant according to paired t-tests. For this reason the mean duration of each short vowel was calculated on all vowels in both syllable contexts in the length relationships expressed as percentage.

Differences in duration between long and short vowels are considerable. A short vowel is in most cases less than 60% of a long one. Length distinctions have a crucial importance in the morphophonemic

system. This is particularly obvious in the verbal system, where differences in length of vowels or consonants often are the only distinguishing feature between the so called derived forms of the verb, the function of which is to change the meaning of the verbal root into various semantic categories. As an example of distinctive length in both vowels and consonants we have the trilateral root ʔtʕ , which forms the verbs / ʔaʕaʕ /, 'to cut', / ʔaʕʕaʕ /, 'to cut to pieces', and / ʔaʕiʕ /, 'to interrupt'. Stress is on the first syllable for all three verbs. In the third form there is also a difference in the short vowel. A minimal set with difference in vowel length only is / kafa /, 'to be enough', / kaffa /, 'to suffice' and / kaafa /, 'to recompense'. Here, stress is also on the first syllable for all verbs. The large differences in both vowel and consonant length in Egyptian Arabic, together with more or less pronounced differences in quality between long and short vowels, could be seen as a way of safe-guarding these semantic distinctions.

Port et al. (1980) found an even larger difference in Arabic in minimal pairs where phonemic vowel length was the distinctive feature. At neutral tempo the V/VV ratio was 1:2.3 and the ratio found in the present study, 1:1.8, was found in fast speech.

Al-Ani (1970;75) reports data that seem to be derived from slow speech. The relative difference between long and short vowels is quite large, however, the long vowels being at least twice as long as the short ones.

Obrecht (1968;29) found that long vowels are twice as long, or slightly less, in Lebanese Arabic. This length relation applies also to consonants.

The rather large durational differences in Egyptian Arabic are not surprising considering the position of duration in the phonemic system compared with other languages. Eiert (1964:110) has made a classification of languages into three groups depending on the position of quantity in various phonemic systems. Group one consists of languages where the stressed vowel alone has information about the quantity distinction. Danish and German belong to this group. In the second group, where Eiert gives Czech, Finnish and Hungarian as examples, vowels and consonants can appear independently in different quantity degrees. Czech is not a very good example to include in this class, however, since only vowels have this property. Consonants do not appear in contrastive quantity degrees (Kučera 1961;24). The third group consists of languages where at least stressed syllables display a regularity with long vowels being followed by short consonants and short consonants by long vowels. As examples of the last group we find Italian, Norwegian and Swedish. By the regular correlation between adjacent vowels and consonants the languages in the third group give information about quantity over more than one segment.

Considering the position of quantity in the phonemic systems of these classes it would seem plausible to suppose greater differences in vowel duration in languages where the length distinction is carried by only one sound segment, than in for example Swedish, where both the

vowel and following consonant give information on quantity. It would also be natural to suppose that differences in duration are greater in languages where the length distinction is based on durational differences only, rather than combined with differences in vowel quality between long and short vowels.

An attempt to compare Egyptian Arabic with the groups defined above shows that it does not fit immediately in any of the three classes suggested by Elert, but is rather split between two of them depending on the relation of vowel length and the number of subsequent consonants. From a superficial point of view Egyptian Arabic belongs to class three in that a long vowel is always followed by a short consonant and thus predictably conveys information on length over more than one segment. Egyptian Arabic also belongs to class two, however, in that a short vowel can be followed by either a long or a short consonant making the vowel the only segment that carries information on length distinction in this case. The relative independence of C and V in Egyptian Arabic suggests that a classification in group two is preferable.

Considering these facts one would suppose greater durational differences in length relations in Egyptian Arabic than in Swedish despite the regularity of Egyptian Arabic in length relations between long vowels and the subsequent consonant. This is also the case. There seems to be more than one reason for this. Firstly, short stressed vowels carry the length distinction alone, since the following consonant does not stand in a regular temporal relation to the preceding vowel. Secondly, the difference in vowel quality between some pairs of long and short vowels, particularly /aa/ and /a/ is not very great. This can be seen on the formant charts 12 and 13 showing plain and emphatic vowels in chapter 5 on vowel quality, where /aa/ and /a/ show considerable overlapping. Vowel length without support from differences in vowel quality as an additional perceptual cue, must be supposed to require relatively larger durational differences. This can be seen from a comparison between Swedish, English and Egyptian Arabic. Swedish, which combines vowel length with a compensatory pattern of length in the following consonant, in addition to rather large differences in quality, has short vowels which vary from 62 % to 77 % of a long vowel according to Elert (1964). In English, with prominent quality differences, which go together with length differences, a short vowel is on the average 77 % of a long one (Wiik 1965; 114). Egyptian Arabic short vowels, on the other hand, are much shorter and vary between 53 % and 60 % of the long ones, with an average of 56 %.

Languages in group two, according to Elert's classification, where vowels and consonants occur independently of each other in different lengths, could be expected to display rather large durational differences. There are several examples of this in completely unrelated languages. Abramson (1960) describes Thai, where vowels can occur as double segments but not consonants. Long vowels were found to be anything from 2 to 3.5 times as long as short ones. Even in running

discourse, where there was no control of the phonemic environments of the contrasts, the ratio was as high as 2.57, (op.cit.;133).

Hungarian short vowels vary between 55 % and 62 % of long ones and are on the average 59 % of long ones or 1:1.7 (Magdics 1969;16), which is very close to Egyptian Arabic values.

Finnish is another language where the phonemic quantity distinction is based on durational differences, excluding other phonetic correlates. Lehtonen (1970) has shown that the difference between long and short vowels in the first syllable in disyllabic words of the same structure as in the present investigation is quite large, a short vowel being 46 % of a long one, a ratio of 1:2.2, which confirms an earlier investigation by Wiik (1965). The relation is the same in other words of different syllable structures and length. As in Thai the ratio is maintained even in continuous speech. This ratio, where a long vowel is at least twice as long as a short one, has had its distinctive temporal function in the phonemic system confirmed in perceptual tests, where listeners have been shown to use length, not vowel quality, as the decisive cue of quantity (Lehtonen, op.cit.; 89).

Engstrand (1986) investigated duration in Czech, Finnish and Swedish in relation to shifting sentence stress. Minimal pairs contrasting in quantity (e.g. [vi:lɑ] versus [vɪlɑ] in Czech and Swedish) were recorded in a sentence frame permitting a systematic shift of stress on the test words into focus and out of focus. The results show that Swedish, with its correlation of quantity and quality, only makes the durational distinction systematically in stressed position. In unstressed positions some speakers still do, whereas others fail to distinguish between long and short vowels as well as long and short consonants. There are obviously tendencies in Swedish that meet the criteria for a classification in group one according to Elert.

Hadding-Koch and Abramson (1964) also found that the phonemic length distinction in Swedish, although clearly a distinctive feature, does not pervade the whole vowel system.

These tendencies are visible also in Dutch, which belongs to group one according to Elert's classification. Engstrand's results confirm Nooteboom's (1972;28f) findings for Dutch where the durational distinctions are subject to weakening or neutralization due to shifting stress and position.

In Czech (Engstrand, op.cit.) on the other hand, long vowels have significantly longer duration than short ones under both conditions of stress.

Finnish (Engstrand, op.cit.) also differentiates between long and short vowels regardless of the position of sentence stress. The durational difference is significant for all speakers in the material. Thus the length distinction is an invariant prosodic property of Finnish with no sign of neutralization in the absence of stress.

Engstrand's findings thus fit well with the language classification of Elert and the predictions about duration in different languages one can make from it.

Hausa, which is distantly related to Arabic, has recently had its vowel system investigated by Lindau (1985) and shows another kind of temporal difference compared with Egyptian Arabic. In Hausa the durations of short vowels differ significantly between open and closed syllables. This is in contrast to Egyptian Arabic, in which vowel length does not differ in these types of syllables. A comparison between Egyptian Arabic and Hausa shows that the length of short vowels in the open syllable in Hausa corresponds to short vowel length in Egyptian Arabic, even if it is somewhat shorter. A vowel in this type of syllable is on the average 52 % of a long vowel in Hausa. A short vowel in closed syllables is still shorter, only 45 % of a long one.

8.2.4. Duration depending on the following consonant.

An often encountered phenomenon is the compensatory relation between voicing in a consonant and length in a preceding vowel. Vowels are often shorter when they occur before voiceless consonants than they are before voiced ones. English is a language where this has been extensively investigated. In English the durational gap is very large, as demonstrated by Peterson and Lehiste (1960) among many others. They report a ratio of roughly 2:3 referring to vowels preceding voiceless/voiced consonants. This is clearly above the auditory threshold according to Lehiste (1970). Wiik's research (1965) shows even larger differences for English. He found that vowels are 82 % longer before a voiced consonant. These differences are so large that they can serve as the sole perceptual cue to the phonemic distinction between voiceless and voiced consonants in English (Denes 1955). These large differences seem to be a specific feature of English. Data for Swedish reported by Elert (1964;134) show much smaller differences. Long vowels differ based on the voiceless/voiced distinction, but at a low significance level ($p < 0.05$). Short vowels also differ, but with higher significance ($p < 0.05$).

Hungarian shows another picture where vowels behave differently depending on length. According to the durational values of Magdics (1969;16), long vowels in interconsonantal position differ significantly depending on the following consonant ($p < 0.05$), but the differences between short vowels are non-significant.

The differences in Egyptian Arabic are consistently very small, varying between one and seven milliseconds for both long and short vowels.

Mean vowel duration in milliseconds and results of t-tests are listed in the following table. Type of stop and its quantity is indicated after the vowel. There are five degrees of freedom unless otherwise stated.

aa-t	aa-d	a-tt	a-dd	a-t	a-d
151	156	88	93	89	95

T-tests:

long /aa/ before /t/ and /d/:	t=-0.766	n.s.
short /a/ before /tt/ and /dd/:	t=-1.181	n.s.
short /a/ before /t/ and /d/:	t=-2.144	n.s.

ii-t	ii-d	i-tt	i-dd	i-t	i-d
150	149	77	80	79	84

T-tests:

long /ii/ before /t/ and /d/:	t= 0.301	n.s.
short /i/ before /tt/ and /dd/:	t= 0.789	n.s.
short /i/ before /t/ and /d/:	t= 1.742	n.s.

uu-ṭ	uu-d	u-tt	u-dd	u-t	u-d
135	158	83	81	87	87

T-tests:

long /uu/ before /ṭ/ and /d/:	t=3.242	p<0.05
short /u/ before /tt/ and /dd/:	t=0.530	n.s.
short /u/ before /t/ and /d/:	t=0.165	n.s.

ee-d	160	oo-d	158
------	-----	------	-----

Table 8-C. Mean duration of long and short vowels preceding voiceless and voiced stops.

The differences are far below the level of significance. Long /uu/ preceding /ṭ/ is an exception here. Its mean value before /ṭ/ is 135 milliseconds, while /uu/ before /d/ is 158 milliseconds. Long /aa/ and /ii/ preceding /t/ are 151 and 150 milliseconds, respectively, and are not significantly distinct before /t/ and /d/. The difference between /uu/ on the one hand and /aa, ii/ on the other in relation to the following /t/, has a low significance level, $0.01 \leq p < 0.05$. A possible explanation might be that /uu/ happens to be followed by an emphatic consonant in the test-word, /fuuṭa/. Emphatic consonants are not found in this position in other test-words. It cannot be established with certainty whether its presence influences the length of the preceding vowel or whether the shorter mean value of /uu/ is due to some other factor.

The short vowels show unanimously the same pattern as long /aa/ and /ii/ in both environments. No short vowel differs in length depending on the voicing of the following consonant.

Port et al. (1980) performed an experiment to study compensatory phenomena in Arabic and Japanese. Two Egyptians, two Iraqis and one

Kuwaiti read the testwords /kataba/-/kadara/ and /kaataba/-/kaadara/ in Standard Arabic as part of the test. Both long and short vowels showed significantly lengthened duration when preceding a voiced stop in slow, neutral and fast speech. The stops on the other hand, did not show any significant durational differences in the three tempos. These results totally contradict the findings of the present investigation of both vowels and intervocalic stops.

The authors note that their results are at variance with another investigation of the same type (Flege 1981), where tests with five Saudi Arabians did not produce any significant durational differences in monosyllabic words ending in /t/ and /d/. In another experiment on Arabic-accented English (Port and Mittleb 1980) it was found that Jordanians pronounced the vowel in CVC words in English, like 'bat' and 'bad', with very small and nonsignificant durational differences. This confirms results from informal tests in Lund on Jordanian Arabic, which showed no significant differences in length in vowels preceding voiced and voiceless stops (professor Eva Gårding, personal communication).

Port et al. suggest a difference in influence on a preceding vowel in Arabic, depending on whether it is followed by an intersyllabic stop or a syllable-final stop in a CVC syllable. The present research investigated disyllabic words, where vowels preceding intersyllabic post-stress stops as in Port et al. were measured, but they nevertheless behave very differently from the trisyllabic words in the cited investigation. It is difficult to assume that Standard Arabic or any dialect has intraspecific rules for durational relationships between vowels and consonants of the kind under discussion, based on the number of syllables in the word. It is quite conceivable, however, that dialects might differ in their timing strategies. Since experimental studies on Arabic dialects still are limited this cannot be established with certainty. The results in Port et al. may depend on the fact that the five speakers represented three nationalities with rather marked differences between their dialects. The speakers recorded the test material in fuṣḥā, or Standard Arabic, and with the choice of test words there would probably be little or no difference on the segmental level, but it is possible that different temporal rules apply to respective dialects, which influence the pronunciation of fuṣḥā and give the presented results when results of measurements are pooled together. The speakers may also have suppressed their temporal dialectal habits in exchange for other durational relations typical for the formal Standard Arabic.

Whatever the reasons for the results in Port et al. they confirm the findings in the present research that a compensatory relationship between vowels and consonants does not exist in the investigated variants of Arabic. This problem is further discussed in section 8.2.6 on duration of intervocalic consonants.

In the same study (Port et al.), Japanese was also investigated. Dentals, including /t/ and /d/ were flanked by /a/ and /u/ in disyllabic

words. The results show that Japanese, like English, displays a compensatory relationship between vowels and following consonants. /d/ is consistently shorter than /t/ and vowels are significantly longer when preceding /d/ than /t/ and thus show the complementary inverse relationship between vowel duration and consonant voicing. There is even evidence of compensatory effects on both adjacent vowels depending on the duration of the intervocalic stop.

As has been mentioned above there are also differences in temporal patterns between syllable types with identical consonantal environments where long vowels display durational compensation, whereas short vowels do not, like in Hungarian. Hausa is another language displaying this picture (Lindau 1985). Egyptian Arabic on the other hand, does not show any differences in either long or short vowels.

A comparison between Egyptian Arabic and other languages show that timing strategies for vowels preceding stops vary within wide limits. The complementary effects on adjacent vowels and stops in English and other languages, depending on voicing in the following consonant, have led to the proposal, for example by Chomsky and Halle (1968), that this phenomenon is universal. Egyptian Arabic and some of the compared languages do not support this hypothesis.

The picture is much more complicated. We find languages like English with very obvious and large compensatory relations. Other languages do not have the same large differences, but show the same tendency, like Swedish and Japanese. Some languages show compensatory relations in long syllables, but not in short ones, like Hausa and Hungarian. Egyptian Arabic does not show compensatory relations in neither long nor short syllables.

The concept of compensatory relations between vowels and voicing in post-vocalic consonants has been critically examined. Lehtonen (1970:79) performed experiments for Finnish with intervocalic /t/ and /d/ in nonsense words and a few real words. He found that a voiced stop has a slight lengthening effect on the preceding vowel. He does not interpret these relations as a necessary consequence of voicing. The same tendency can be found together with other consonants which influence the duration of the preceding vowel according to their own intrinsic length. The shorter the intrinsic length of a consonant, the shorter the preceding vowel tends to be, and vice versa.

Vowel length has not been found to be related to differences in duration in consonants although /t/ is significantly shorter than /d/ in Egyptian Arabic. The lengthening of vowels preceding voiced consonants could be a natural consequence of the physiologically conditioned consonant relationship (see 8.2.6). Even Egyptian Arabic shows the same tendency, even if it is very small and nonsignificant. This tendency can be used for linguistic purposes, as in English, where the differences in vowel length are increased to serve as a cue for voicing. Egyptian Arabic on the other hand does not make use of this natural tendency, which is kept within the time boundaries set by the articulatory process. The phonemic length distinction in Egyptian Arabic is used to

create oppositions on another level in the morphophonemic system than in English and other languages exhibiting the compensatory phenomenon. A compensatory relationship depending on voicing in a following consonant might compete with length distinctions signalling different verb categories, for example.

The prominent compensatory relationship between vowels and voicing in postvocalic consonants in for example English and to a lesser degree in Swedish on the one hand, and the partial or non-existing compensation as in Hausa and Egyptian Arabic support the view that rules for durational patterning are language-specific.

8.2.5. Intrinsic length.

A phenomenon in many languages is the existence of systematic differences in duration between different vowels in identical surroundings. These properties of the vowels have been related to their phonetic quality and are generally referred to as intrinsic length. Lehiste (1970:18) reports a number of investigations where vowel duration has been found to correlate with the dimension high-low in such a way that high vowels are shorter than low vowels. According to these data long /ii/ should be expected to be shorter than long /uu/, which is shorter than long /aa/. The pattern is the same for short vowels as well.

Intrinsic vowel length can be correlated to physiological properties of the speech production mechanism. Lindblom (1967) has shown with his model of lip-mandible coordination that low vowels are longer than high vowels due to the large mandibular movements for low vowels. The off-glide gesture of the mandible after a low vowel into a following consonant also progresses so slowly that there is a delay before the articulators are able to come in contact and produce the consonant.

The same relationships have been reported for a number of unrelated languages, such as Hungarian (Magdics 1969), English (Peterson and Lehiste 1962) and Thai (Abramson 1960), to name but a few investigations. The following mean durations in milliseconds from Eiert (1964:123) show intrinsic length relations between Swedish vowels, measured before /t/ and /s/. They are fairly representative for other languages where the same relations occur.

	long vowels	short vowels
/i y o/	140	95
/e u å/	155	103
/ä ö a/	164	111

One can ask if the known data are so uniform that it is possible to establish the characteristic pattern of intrinsic length as a universal feature.

In Egyptian Arabic all long vowels vary within very narrow limits, with mean values from 149 to 160 milliseconds, with the exception of /uu/ preceding /t/, which is somewhat shorter than the others, but with a low significance level, ($p < 0.05$) when compared with /uu/ preceding /d/. This is obvious in figure 26 where all long vowels can be seen to have a very uniform duration over the whole range of different qualities. Since long /ii/ and /aa/ do not differ in length whether preceding a voiced or a voiceless stop, and /uu/ differs only at a low level of significance, durations for each long vowel, regardless of the type of the postvocalic consonant, have been collapsed and counted in the same group. The same procedure has been performed with regard to the short vowels for the same reasons. Paired t-tests were then performed between long and short vowels respectively, in all possible combinations. Long vowels do not in any case reveal significant durational differences which can be attributed to intrinsic length. The durational means and the results of paired t-tests for the long vowels are given in the following table:

Means:

/aa/ before /t/: 151 ms.

/aa/ before /d/: 156 ms.

collapsed: 153 ms.

/ii/ before /t/: 150 ms.

/ii/ before /d/: 149 ms.

collapsed: 150 ms.

/uu/ before /t/: 135 ms.

/uu/ before /d/: 158 ms.

collapsed: 146 ms.

T-tests:

aa/ii t= 0.698 n.s. 11 df

aa/uu t= 1.099 n.s. 11 df

aa/ee t= 0.509 n.s. 5 df

aa/oo t= 0.272 n.s. 5 df

ii/uu t= 0.672 n.s. 11 df

ii/ee t=-2.569 n.s. 5 df

ii/oo t= 1.967 n.s. 5 df

uu/ee t= 0.452 n.s. 5 df

uu/oo t= 0.034 n.s. 5 df

ee/oo t= 0.934 n.s. 5 df

Table 8-D. Mean duration of long vowels preceding voiceless and voiced stops. Comparison between long vowels by paired t-tests.

Contrary to the long vowels, the short vowels all show the expected differences according to the relations as described by Lehiste (op.cit.). /i/ is shorter than /u/, which is shorter than /a/, which is the longest of the short vowels. Mean values of short vowels are given in the following table:

preceding /t/	preceding /d/	collapsed
/a/ 89 ms.	94 ms.	92 ms.
/i/ 78 ms.	82 ms.	80 ms.
/u/ 85 ms.	84 ms.	85 ms.

a/i	t=6.292	p<0.001	23 df
a/u	t=2.649	p<0.05	20 df
u/i	t=3.079	p<0.01	20 df

Table 8-E. Mean duration of short vowels preceding voiceless and voiced stops. Comparison between short vowels by paired t-tests.

It could also have been expected, according to Lehiste's data (op.cit.:18), that /aa/ should have a longer duration in a plain environment, where it is mostly realized as [æ:], than in an emphatic environment, where it is mostly realized as [a:]. T-tests, however, do not reveal any significant differences, and these different vowel qualities thus conform to the general pattern of long vowels with regard to intrinsic length.

Another way of demonstrating intrinsic vowel length was proposed by Maack (1949). He proposed $\bar{X}_v/\bar{X}_{all\ v}$ as an indicator of the intrinsic duration value. In this way it is possible to compare the durational mean of a vowel to the mean of all vowels, expressed as a ratio. This ratio is shown in the following table for Egyptian Arabic long and short vowels. Since vowels do not differ significantly depending on the following consonant, except long /uu/, the mean of each vowel is calculated regardless of the following consonant. Long /uu/ is shown in two ways. Firstly presented in the same way as the other long vowels, without consideration to its low level significant differences depending on the following consonant, secondly with regard to its durational differences preceding /t/ and /d/.

/aa/:	1.01	/a/:	1.07
/ii/:	0.99	/i/:	0.94
/uu/:	0.96	/u/:	1.00
/uu/ preceding /t/:	0.89		
/uu/ preceding /d/:	1.04		

Table 8-F. Intrinsic duration value of long and short vowels.

This table over the ratios underlines what has been found through the t-tests. Both indicate the same characteristic properties of long and short vowels. There is a dichotomy, where long vowels have a more

or less uniform length in contrast to short vowels, which exhibit the expected temporal relationships, high vowels being shorter than long ones.

This result has been found to hold also for Finnish (Lehtonen 1970). Durational differences between long vowels, related to different degrees of openness, are levelled out to obtain a more or less uniform length. It seems as if long vowels in both Finnish and Egyptian Arabic have an ideal length within narrow limits, which has to be observed by speakers. It is likely that the prolonged duration of long vowels overcomes any influence of inherent length.

One can discuss whether any particular vowel determines this ideal length. It is difficult to decide, but it is possible that long /aa/, which in all cross-linguistic investigations is the longest vowel due to its relatively slow articulatory gestures related to the jaw, determines the durational target for long vowels in Egyptian Arabic. The other long vowels would then have to sustain their duration to reach the same length.

Short vowels on the other hand, are not influenced by any levelling factors, but are allowed to be as short as it is physiologically possible to produce them. They therefore show the same typical relationships, which have been found in many other languages. As has been pointed out in an earlier section, both Egyptian Arabic and Finnish belong to a category of languages where phonemic length is a phonetically prominent feature. Great durational differences due to intrinsic length might disturb the balance in the system and cause confusion. To keep the important long-short distinction intact, long vowels have to get close to an ideal target.

8.2.6. Duration of intervocalic consonants.

Voiceless consonants have been shown to be longer than voiced consonants in nearly all languages where consonant duration has been measured (Elert 1964:148). There are suggested physiological explanations for this (Catford 1982:74,128). During production of voiced stops the difference between the subglottal and supraglottal pressure is quickly abolished since air passes through the glottis and cannot escape because of the oral closure. One way of prolonging the duration of a voiced stop is to lower the larynx or in other ways expand the pharynx. A voiceless stop on the other hand can be prolonged for a considerably longer period. It is therefore no surprise that a comparison between the intervocalic stops in Egyptian Arabic shows that /t/ is consistently and significantly longer than /d/. The difference is only upheld when the stops occur as single consonants, and in no case is there any significant difference between voiced and voiceless geminate consonants.

t/d after /aa/	t= 4.677	p<0.01	5 df
t/d after /a/	t= 8.300	p<0.001	5 df
t/d after /ii/	t=13.103	p<0.001	5 df
t/d after /i/	t= 2.673	p<0.05	5 df
t/d after /uu/	t= 3.928	p<0.05	5 df
t/d after /u/	t= 4.020	p<0.05	4 df
tt/dd after /a/	t= 0.544	n.s.	5 df
tt/dd after /i/	t= 0.798	n.s.	5 df
tt/dd after /u/	t= 2.480	n.s.	3 df

Table 8-G. Paired t-tests of t/d and tt/dd in intervocalic position.

It can be seen that geminated voiced and voiceless consonants do not show any significant differences in length, regardless of the quality of the preceding vowel. This is obvious on Figure 26. Long intervocalic consonants are true geminates of roughly twice the length of a single consonant, with a duration of 150-160 milliseconds. Single voiceless stops are roughly 53% of long ones. Single voiced stops are shorter, varying between 32% and 40% of long ones.

Finnish does not have the phonological opposition between voiced and voiceless stops and duration cannot be compared between these classes. The relation between a long and a short voiceless stop, however, is as large as in Egyptian Arabic. Lehtonen (1970:97) calculated a mean ratio for Finnish voiceless stops and /s/, which was found to be 1:1.99, i.e. long stops are roughly twice as long as short ones.

Other languages with voiced-voiceless contrast, show significant durational differences not only for short stops, but also for long ones, for example Hausa (Lindau 1985). Swedish is another language with the expected durational difference between /t/ and /d/. This difference applies also when these stops occur as long intervocalic consonants. Elert (1964) and Löfqvist (1976) give examples of these relations between /tt/ and /dd/, in addition to other geminated Swedish phonemes, preceded by different vowels.

When occurring as geminates, /tt/ and /dd/ do not differ significantly in length. It is likely that the prolonged occlusion of geminated stops overcomes any influence of factors of inherent length determining the duration of single consonants. This appears to be a parallel to vowel length. Long vowels do not differ significantly in length regardless of quality, and appear to have an ideal durational target, to which factors related to intrinsic length are subordinated. Long consonants seem to behave in the same way in subordinating factors of intrinsic length to reach an ideal target when geminated. Not only the relation, but even the absolute values are approximately the same for long vowels and consonants, varying between 150 and 160 milliseconds in this kind of conversational speech rate. Short consonants, on the other

hand, are assumed to be like the short vowels in that they are allowed to be produced as fast as is physiologically possible.

Appendix

saadis	'sixth'	şaađı?	'just'
zaakir	'mentioning'	zaalim	'tyrant'
saad	'govern'	sadd	'close'
zeet	'oil'	zetha	'her oil'
siid	'lord'	sitt	'lady'
looz	'almonds'	lozha	'her almonds'
suud	'black' (pl.)	sudd	'close!'
şaad	'to hunt'	şadd	'to prevent'
şeed	'hunting'	sooda	'black'
şiiit	'reputation'	şitt	artificial word
şoot	'voice'	şeeda	'prey'
şuud	artificial word	şudd	'prevent!'
?işaaş	'punishment'	?işaşha	'her stories'
taxşiiş	'specialization'	?aşişha	'he punished her'
maxşuuş	'special'	şuşuşha	'her coccyx'
siit	artificial word	şiiit	'reputation'
suud	'black'	şuud	artificial word
sadd	'to close'	şadd	'to prevent'
sitt	'lady'	şitt	artificial word
sudd	'close!'	şudd	'prevent!'
faatı	'they passed'	şita	'winter'
saadu	'they governed'	sidi	artificial word
fattu	'they cut'	fuuşa	'towel'
saddu	'they closed'	suudu	'govern!'
futtu	'jump!'	fata	'give a legal decision'
sada	'warp'	suddu	'prevent!'
şiiiti	'my reputation'	futa	artificial word
siidi	'my lord'	suda	artificial word

TABLE 1.

Center of gravity, dispersion and mean intensity level of critical band spectra of voiced and voiceless sibilants.

		<u>center of gravity</u>		dispersion	mean intensity level in dB
		crit.band units:	Hz:		
/s/	Sp. 1	20.55	5681	2.15	4.24
	Sp. 2	21.18	6219	1.48	7.18
	Sp. 3	21.53	6540	1.80	4.91
	Sp. 4	20.83	5914	1.75	13.06
	Sp. 5	21.83	6827	0.95	7.74
	Sp. 6	<u>21.98</u>	<u>6976</u>	<u>1.09</u>	<u>6.36</u>
	Mean:	21.32	6345	1.54	7.25
/ʃ/	Sp. 1	20.59	5714	2.63	2.55
	Sp. 2	20.90	5974	1.56	1.44
	Sp. 3	20.99	6052	2.31	1.22
	Sp. 4	20.71	5813	1.90	13.66
	Sp. 5	21.39	6410	1.46	7.88
	Sp. 6	<u>20.80</u>	<u>5889</u>	<u>1.77</u>	<u>6.73</u>
	Mean:	20.90	5974	1.94	5.58
/z/	Sp. 1	18.36	4143	4.61	-5.84
	Sp. 2	21.51	6521	1.23	4.50
	Sp. 3	21.85	6847	1.18	8.80
	Sp. 4	19.87	5151	2.90	0.70
	Sp. 5	19.62	4969	5.44	-5.67
	Sp. 6	<u>21.74</u>	<u>6740</u>	<u>1.62</u>	<u>5.73</u>
	Mean:	20.49	5632	2.83	1.37
/ʒ/	Sp. 1	15.22	2622	6.49	-2.35
	Sp. 2	20.52	5656	1.97	2.49
	Sp. 3	20.66	5771	3.57	-0.71
	Sp. 4	20.76	5855	2.17	7.84
	Sp. 5	21.11	6157	1.39	1.60
	Sp. 6	<u>19.45</u>	<u>4849</u>	<u>5.73</u>	<u>-5.23</u>
	Mean:	19.62	4969	3.55	0.60

TABLE 2.

Duration of long and short plain and emphatic vowels in monosyllabic words in milliseconds. Five tokens of each speaker, mean and standard deviation. Seven degrees of freedom, unless otherwise stated.

1)		Plain long /aa/.					
Token	1	2	3	4	5	\bar{X}	SD
Sp. 1	150	148	145	210	172	155	11
Sp. 2	204	205	214	210	-	208	5
Sp. 3	-	183	180	209	179	188	14
Sp. 4	128	170	159	180	188	165	23
Sp. 5	-	230	166	226	170	198	35
Sp. 6	132	142	152	123	150	140	12
Sp. 7	185	188	166	172	172	177	9
Sp. 8	136	146	162	136	120	<u>140</u>	<u>15</u>
Mean:						171	26

2)		Emphatic long /aa/.					
Token	1	2	3	4	5	\bar{X}	SD
Sp. 1	158	168	158	158	160	160	4
Sp. 2	184	176	210	212	-	196	18
Sp. 3	166	164	170	176	169	169	5
Sp. 4	160	152	162	158	159	158	4
Sp. 5	150	168	162	183	196	172	18
Sp. 6	144	130	152	152	143	144	9
Sp. 7	192	168	164	172	172	174	11
Sp. 8	146	132	147	136	134	<u>139</u>	<u>7</u>
Mean:						164	18

t-test plain /aa/ and emphatic /aa/: $t=1.898$, n.s.

3)		Plain long /ii/.					
Token	1	2	3	4	5	\bar{X}	SD
Sp. 1	122	126	144	149	136	135	11
Sp. 2	162	202	200	215	-	195	23
Sp. 3	180	152	163	170	164	166	10
Sp. 4	-	140	174	146	162	156	15
Sp. 5	158	148	146	135	155	148	9
Sp. 6	105	118	-	140	105	117	17
Sp. 7	154	154	167	158	138	127	10
Sp. 8	128	122	128	133	136	<u>129</u>	<u>5</u>
Mean:						147	25

4) Emphatic long /ii/.

Token	1	2	3	4	5	\bar{x}	SD
Sp. 1	125	134	144	140	142	137	8
Sp. 2	160	155	185	192	-	173	18
Sp. 3	115	134	149	108	133	128	16
Sp. 4	-	120	141	132	140	133	10
Sp. 5	108	130	140	132	140	130	13
Sp. 6	144	144	172	148	147	151	12
Sp. 7	128	136	148	148	148	142	9
Sp. 8	140	136	134	105	-	<u>129</u>	<u>16</u>
Mean:						140	15

t-test plain /ii/ and emphatic /ii/: $t=0.753$, n.s.

5) Plain long /uu/.

Token	1	2	3	4	5	\bar{x}	SD
Sp. 1	133	142	156	146	144	144	8
Sp. 2	165	205	180	184	-	184	17
Sp. 3	176	178	165	192	176	177	10
Sp. 4	128	136	126	159	154	141	15
Sp. 5	190	-	172	198	194	189	11
Sp. 6	-	140	120	110	152	131	19
Sp. 7	176	154	184	158	186	172	15
Sp. 8	144	120	152	132	126	<u>135</u>	<u>13</u>
Mean:						159	24

6) Emphatic long /uu/.

Token	1	2	3	4	5	\bar{x}	SD
Sp. 1	136	139	146	158	150	146	9
Sp. 2	-	176	196	194	-	189	11
Sp. 3	152	152	180	192	188	173	19
Sp. 4	132	133	140	128	135	134	4
Sp. 5	192	218	160	168	165	181	24
Sp. 6	128	-	126	126	106	122	10
Sp. 7	182	-	163	151	179	169	14
Sp. 8	148	144	150	128	130	<u>140</u>	<u>10</u>
Mean:						157	24

t-test plain long /uu/ and emphatic long /uu/: $t=1.177$, n.s.

7) Plain short /a/.

Token	1	2	3	4	5	\bar{X}	SD
Sp. 1	104	110	96	-	112	106	7
Sp. 2	99	98	100	104	-	100	3
Sp. 3	75	74	74	68	79	74	4
Sp. 4	89	102	108	101	-	100	8
Sp. 5	79	86	68	81	92	81	9
Sp. 6	85	82	70	79	84	80	6
Sp. 7	108	126	116	-	126	119	9
Sp. 8	-	103	111	100	90	<u>101</u>	<u>9</u>
Mean:						95	15

8) Emphatic short /a/.

Token	1	2	3	4	5	\bar{X}	SD
Sp. 1	88	89	98	101	104	96	7
Sp. 2	90	100	94	98	98	96	4
Sp. 3	94	72	75	78	75	79	9
Sp. 4	76	114	-	106	116	103	19
Sp. 5	88	94	85	92	80	88	6
Sp. 6	100	96	88	92	95	94	4
Sp. 7	-	120	102	104	-	109	10
Sp. 8	94	-	-	97	97	<u>96</u>	<u>2</u>
Mean:						95	9

t-test short plain /a/ and short emphatic /a/: t=0.000, n.s.

9) Plain short /i/.

Token	1	2	3	4	5	\bar{X}	SD
Sp. 1	61	67	58	69	73	66	6
Sp. 2	74	81	80	82	89	81	5
Sp. 3	60	61	54	63	56	59	4
Sp. 4	77	67	76	84	88	78	8
Sp. 5	72	60	62	61	72	65	6
Sp. 6	61	69	57	68	65	64	5
Sp. 7	86	82	92	82	93	87	6
Sp. 8	85	75	84	75	-	<u>80</u>	<u>6</u>
Mean:						73	10

10) Emphatic short /i/.

Token	1	2	3	4	5	\bar{X}	SD
Sp. 1	66	68	64	77	69	69	5
Sp. 2	94	80	94	78	-	87	9
Sp. 3	66	60	67	64	66	65	3
Sp. 4	83	94	-	92	88	89	5
Sp. 5	-	-	-	-	-	-	-
Sp. 6	83	94	-	-	94	90	6
Sp. 7	-	-	-	-	-	-	-
Sp. 8	76	78	81	80	81	<u>79</u>	<u>2</u>
Mean:						80	11

t-test plain short /i/ and emphatic short /i/: $t=2.206$, n.s. 5 d.f.

11) Plain short /u/.

Token	1	2	3	4	5	\bar{X}	SD
Sp. 1	72	86	82	96	92	86	9
Sp. 2	82	80	88	89	98	87	7
Sp. 3	78	69	66	65	69	69	5
Sp. 4	-	94	102	100	102	100	4
Sp. 5	76	76	78	76	80	77	2
Sp. 6	100	82	96	103	88	94	9
Sp. 7	88	80	75	64	75	76	9
Sp. 8	88	103	89	84	89	<u>91</u>	<u>7</u>
Mean:						85	10

12) Short emphatic /u/.

Token	1	2	3	4	5	\bar{X}	SD
Sp. 1	82	84	78	96	100	88	9
Sp. 2	86	88	94	98	100	93	6
Sp. 3	67	64	60	65	61	63	3
Sp. 4	60	84	89	104	92	86	16
Sp. 5	72	72	65	74	74	71	4
Sp. 6	78	86	88	91	80	85	5
Sp. 7	80	68	62	-	84	74	10
Sp. 8	84	104	78	82	76	<u>85</u>	<u>11</u>
Mean:						80	11

t-test short plain /u/ and emphatic short /u/: $t=1.971$, n.s.

TABLE 3

Duration of vowels and intervocalic consonants in disyllabic words in milliseconds.

Three tokens of each speaker, mean and standard deviation.

Five degrees of freedom, unless otherwise stated.

		1) aa-t									
Token	1		2		3		\bar{x}		SD		
	aa	t	aa	t	aa	t	aa	t	aa	t	
Sp. 1	144	80	148	88	144	96	145	88	2	8	
Sp. 2	162	99	160	92	152	92	158	95	5	5	
Sp. 3	162	88	168	96	172	86	167	90	5	5	
Sp. 4	118	82	136	80	108	76	120	79	3	14	
Sp. 5	160	92	144	96	140	80	148	89	11	8	
Sp. 6	166	72	174	76	162	68	<u>167</u>	<u>72</u>	<u>6</u>	<u>4</u>	
							151	86	18	8	

		2) aa-d									
Token	1		2		3		\bar{x}		SD		
	aa	d	aa	d	aa	d	aa	d	aa	d	
Sp. 1	136	68	144	60	148	60	143	63	6	5	
Sp. 2	188	60	176	68	172	68	179	65	8	5	
Sp. 3	170	72	168	64	168	54	167	63	1	9	
Sp. 4	130	65	152	60	130	60	137	62	13	3	
Sp. 5	160	92	144	96	140	80	148	89	11	8	
Sp. 6	152	52	144	60	146	56	<u>147</u>	<u>56</u>	<u>4</u>	<u>4</u>	
							156	66	16	11	

t-test long /aa/ before /t/ and /d/: $t=-0.776$, n.s.

t-test t/d after long /aa/: $t=4.677$, $p<0.01$.

		3) a-tt									
Token	1		2		3		\bar{x}		SD		
	a	tt	a	tt	a	tt	a	tt	a	tt	
Sp. 1	84	168	92	168	88	176	88	171	4	15	
Sp. 2	84	126	97	105	80	103	87	111	9	13	
Sp. 3	92	176	92	212	96	206	93	198	2	19	
Sp. 4	88	164	78	142	70	142	79	149	9	13	
Sp. 5	104	172	92	172	92	160	96	168	7	7	
Sp. 6	82	152	94	188	86	142	<u>87</u>	<u>161</u>	<u>6</u>	<u>24</u>	
							88	160	6	29	

		4) a-dd								
Token	1		2		3		\bar{X}	SD		
	a	dd	a	dd	a	dd	a	dd		
Sp. 1	88	144	88	156	92	144	89	148	2	7
Sp. 2	95	132	88	132	108	154	97	139	10	13
Sp. 3	94	182	84	202	102	186	93	190	9	10
Sp. 4	93	116	92	114	82	106	89	112	6	5
Sp. 5	120	168	-	-	104	164	112	166	11	3
Sp. 6	80	168	-	-	74	176	<u>77</u>	<u>172</u>	<u>4</u>	<u>6</u>
							93	155	12	28

t-test short /a/ before tt/dd: $t=-1.181$, n.s.

t-test tt/dd after short /a/: $t=0.544$, n.s.

		5) a-t								
Token	1		2		3		\bar{X}	SD		
	a	t	a	t	a	t	a	t		
Sp. 1	84	84	88	88	65	88	79	87	12	2
Sp. 2	100	90	96	82	88	84	95	85	6	4
Sp. 3	88	108	98	90	92	106	93	101	5	10
Sp. 4	80	92	78	80	75	94	78	87	3	8
Sp. 5	100	96	112	88	112	88	108	93	7	5
Sp. 6	88	78	78	68	78	78	<u>81</u>	<u>75</u>	<u>6</u>	<u>6</u>
							89	88	12	9

		6) a-d								
Token	1		2		3		\bar{X}	SD		
	a	d	a	d	a	d	a	d		
Sp. 1	88	58	96	52	92	52	92	54	4	4
Sp. 2	110	40	92	48	102	66	101	51	9	13
Sp. 3	110	62	102	65	92	68	101	65	9	3
Sp. 4	84	60	96	62	80	58	87	60	8	2
Sp. 5	-	-	92	56	114	90	103	73	16	24
Sp. 6	82	68	88	56	78	52	<u>83</u>	<u>59</u>	<u>5</u>	<u>8</u>
							95	60	8	8

t-test short /a/ before /t/and /d/: $t=-2.144$, n.s.

t-test t/d after short /a/: $t=8.300$, $p<0.001$

7) ii-t

Token	1		2		3		\bar{X}		SD	
	ii	t	ii	t	ii	t	ii	t	ii	t
Sp. 1	148	108	142	98	124	110	138	105	13	7
Sp. 2	152	97	148	111	138	96	146	101	6	9
Sp. 3	148	88	148	100	156	92	151	93	5	6
Sp. 4	136	86	158	82	160	94	151	88	13	5
Sp. 5	148	108	138	96	128	102	138	102	10	6
Sp. 6	161	92	184	104	188	83	<u>178</u>	<u>93</u>	<u>15</u>	<u>11</u>
							150	97	15	7

8) ii-d

Token	1		2		3		\bar{X}		SD	
	ii	d	ii	d	ii	d	ii	d	ii	d
Sp. 1	122	80	136	64	136	76	131	73	8	8
Sp. 2	148	64	156	72	140	76	148	71	8	6
Sp. 3	160	42	152	56	168	44	160	47	8	8
Sp. 4	142	60	146	66	165	38	151	55	12	13
Sp. 5	165	66	136	76	130	64	144	67	19	6
Sp. 6	162	68	168	76	152	52	<u>161</u>	<u>65</u>	<u>8</u>	<u>12</u>
							149	63	11	10

t-test long /ii/ before /t/ and /d/: $t=0.301$, n.s.

t-test t/d after long /ii/: $t=13.103$, $p<0.001$.

9) i-tt

Token	1		2		3		\bar{X}		SD	
	i	tt	i	tt	i	tt	i	tt	i	tt
Sp. 1	80	156	76	156	80	144	79	152	2	
Sp. 2	76	148	64	172	68	164	69	161	6	12
Sp. 3	76	176	72	192	82	204	77	191	5	14
Sp. 4	84	170	76	176	72	162	77	168	6	8
Sp. 5	80	170	80	164	82	158	81	164	1	6
Sp. 6	74	158	82	180	72	160	<u>76</u>	<u>166</u>	<u>5</u>	<u>12</u>
							77	167	4	13

Token	10)						i-dd		\bar{X}	SD
	1		2		3					
	i	dd	i	dd	i	dd	i	dd		
Sp. 1	84	148	64	156	72	172	73	159	10	12
Sp. 2	80	152	72	148	68	156	73	152	6	4
Sp. 3	80	144	80	136	80	160	80	146	0	12
Sp. 4	84	154	82	156	84	148	83	151	1	5
Sp. 5	-	-	108	188	96	172	102	180	9	11
Sp. 6	66	166	68	172	70	176	<u>68</u>	<u>171</u>	<u>2</u>	<u>5</u>
							80	160	13	12

t-test short /i/ before tt/dd: $t=0.789$, n.s.

t-test tt/dd after short /i/: $t=0.798$, n.s.

Token	11)						i-t		\bar{X}	SD
	1		2		3					
	i	t	i	t	i	t	i	t		
Sp. 1	92	78	74	77	83	80	83	78	9	2
Sp. 2	74	84	68	92	76	82	73	86	4	5
Sp. 3	82	92	84	88	82	98	83	93	1	5
Sp. 4	78	92	86	80	88	90	83	87	6	6
Sp. 5	70	88	88	80	82	92	80	86	9	6
Sp. 6	66	70	86	70	64	74	<u>72</u>	<u>71</u>	<u>12</u>	<u>2</u>
							79	84	5	8

Token	12)						i-d		\bar{X}	SD
	1		2		3					
	i	d	i	d	i	d	i	d		
Sp. 1	76	72	80	74	88	60	81	69	6	8
Sp. 2	78	56	86	58	94	52	86	55	8	3
Sp. 3	-	-	88	52	90	32	89	42	1	14
Sp. 4	94	50	98	56	-	-	96	53	3	4
Sp. 5	96	70	82	76	84	80	87	75	8	5
Sp. 6	74	72	64	72	68	80	<u>67</u>	<u>75</u>	<u>5</u>	<u>5</u>
							84	62	9	14

t-test short /i/ before /t/ and /d/: $t=1.742$, n.s.

t-test t/d after short /i/: $t=2.673$, $p<0.05$

13) uu-t

Token	1		2		3		\bar{X}		SD	
	uu	t	uu	t	uu	t	uu	t	uu	t
Sp. 1	128	100	140	108	132	92	133	100	6	8
Sp. 2	128	108	128	88	132	88	129	95	2	12
Sp. 3	136	102	118	100	142	114	132	105	12	8
Sp. 4	152	88	144	84	142	96	146	91	5	8
Sp. 5	144	90	112	100	108	86	121	92	20	7
Sp. 6	142	76	140	76	156	80	<u>146</u>	<u>77</u>	<u>10</u>	<u>2</u>
							135	93	13	10

14) uu-d

Token	1		2		3		\bar{X}		SD	
	uu	d	uu	d	uu	d	uu	d	uu	d
Sp. 1	166	60	152	56	168	64	162	60	9	4
Sp. 2	160	64	142	52	142	56	148	57	10	6
Sp. 3	156	48	164	46	166	56	162	50	5	5
Sp. 4	156	64	158	64	142	65	152	64	9	1
Sp. 5	172	76	156	76	184	84	171	79	14	5
Sp. 6	-	-	-	-	152	72	<u>152</u>	<u>72</u>	<u>-</u>	<u>-</u>
							158	64	9	10

t-test long /uu/ before /t/ and /d/: $t=-3.407$, $p<0.05$

t-test t/d after long /uu/: $t=3.928$, $p<0.05$

15) u-tt

Token	1		2		3		\bar{X}		SD	
	u	tt	u	tt	u	tt	u	tt	u	tt
Sp. 1	92	176	76	165	72	176	80	172	11	6
Sp. 2	80	170	72	160	86	166	79	165	7	5
Sp. 3	-	-	-	-	-	-	-	-	-	-
Sp. 4	-	-	-	-	-	-	-	-	-	-
Sp. 5	100	163	102	180	88	160	97	168	8	11
Sp. 6	72	188	80	166	77	162	<u>76</u>	<u>172</u>	<u>4</u>	<u>14</u>
							83	169	4	3

		16) u-d								
Token	1		2		3		\bar{X}	SD		
	u	dd	u	dd	u	dd	u	dd	u	dd
Sp. 1	84	168	78	180	80	172	81	173	3	6
Sp. 2	87	150	76	164	80	154	81	156	6	7
Sp. 3	92	134	-	-	76	156	84	145	11	16
Sp. 4	88	142	74	148	88	156	83	149	9	7
Sp. 5	96	160	116	157	96	167	102	161	12	5
Sp. 6	60	182	60	154	56	160	<u>57</u>	<u>165</u>	<u>2</u>	<u>14</u>
							81	158	14	10

t-test short /u/ before tt/dd: t=0.530, n.s.
t-test tt/dd after short /u/: t=2.480, n.s.

		17) u-t								
Token	1		2		3		\bar{X}	SD		
	u	t	u	t	u	t	u	t	u	t
Sp. 1	84	88	80	93	96	76	87	86	8	9
Sp. 2	80	92	84	88	84	86	83	89	2	3
Sp. 3	96	84	80	80	90	82	89	82	8	2
Sp. 4	88	76	96	84	92	80	92	80	4	4
Sp. 5	-	-	-	-	-	-	-	-	-	-
Sp. 6	82	84	80	72	92	80	<u>85</u>	<u>79</u>	<u>6</u>	<u>6</u>
							87	83	3	4

		18) u-d								
Token	1		2		3		\bar{X}	SD		
	u	d	u	d	u	d	u	d	u	d
Sp. 1	84	64	92	60	86	50	87	58	4	7
Sp. 2	90	46	86	56	80	56	85	53	5	6
Sp. 3	96	44	100	52	108	60	101	52	6	8
Sp. 4	98	54	106	56	100	60	101	57	4	3
Sp. 5	100	108	104	96	88	96	97	100	8	7
Sp. 6	60	66	58	76	50	72	<u>56</u>	<u>71</u>	<u>5</u>	<u>5</u>
							87	65	17	18

t-test short /u/ before t/d: t=0.165, n.s.
t-test t/d after short /u/: t=4.020, p<0.05

19) ee-d

Token	1		2		3		\bar{x}		SD	
	ee	d	ee	d	ee	d	ee	d	ee	d
Sp. 1	144	52	152	48	140	72	145	57	6	13
Sp. 2	148	56	152	64	148	56	149	59	2	5
Sp. 3	160	52	156	56	172	56	163	55	8	2
Sp. 4	176	54	180	30	170	52	175	45	5	13
Sp. 5	168	52	156	60	176	72	167	61	10	10
Sp. 6	154	60	152	72	182	52	<u>163</u>	<u>61</u>	<u>17</u>	<u>10</u>
							160	56	11	6

20) oo-d

Token	1		2		3		\bar{x}		SD	
	oo	d	oo	d	oo	d	oo	d	oo	d
Sp. 1	160	44	144	56	152	28	152	43	8	14
Sp. 2	164	48	146	64	146	56	152	56	10	8
Sp. 3	156	48	160	48	152	52	156	49	4	2
Sp. 4	176	54	174	48	162	52	171	51	8	3
Sp. 5	164	58	160	62	150	56	158	59	7	3
Sp. 6	152	56	168	52	158	41	<u>159</u>	<u>50</u>	<u>8</u>	<u>8</u>
							158	51	7	6

TABLE 4
FORMANT ONSET FREQUENCIES

Mean of three tokens for each speaker, grand mean and standard deviation for nine speakers.

1) /aa/

	CVVC			ÇVVC			ÇVVC		
	F1	F2	F3	F1	F2	F3	F1	F2	F3
Sp. 1	490	1740	2700	525	1210	2360	500	1205	2390
Sp. 2	510	1685	2725	575	1235	2925	585	1195	2935
Sp. 3	490	1760	2560	585	1115	2890	545	1085	2795
Sp. 4	475	1760	2515	515	1110	2515	525	1135	2445
Sp. 5	510	1785	2790	610	1375	2815	575	1415	2765
Sp. 6	475	1700	2490	500	1225	2500	500	1140	2475
Sp. 7	510	1660	2535	460	1015	2500	500	985	2525
Sp. 8	475	1940	2745	585	1205	2750	605	1125	-
Sp. 9	<u>515</u>	<u>1700</u>	<u>2600</u>	<u>565</u>	<u>1020</u>	<u>2920</u>	<u>620</u>	<u>1115</u>	<u>2825</u>
Mean:	495	1750	2630	545	1170	2685	550	1155	2645
	17	83	112	49	115	218	47	117	208

T-tests:	CVVC-ÇVVC	CVVC-ÇVVC	ÇVVC-ÇVVC
F1	-3.193 p<0.05	-3.789 p<0.01	-0.357 n.s.
F2	15.066 p<0.001	14.013 p<0.001	0.632 n.s.
F3	-0.833 n.s.	-0.506 n.s.	1.741 n.s.

2) /a/

	CVC			ÇVC			ÇVC		
	F1	F2	F3	F1	F2	F3	F1	F2	F3
Sp. 1	525	1640	2595	515	1235	2465	545	1200	2390
Sp. 2	535	1595	2740	600	1255	2840	595	1185	2805
Sp. 3	655	1620	2580	595	1075	2800	505	1145	2835
Sp. 4	545	1515	2495	575	1180	2510	575	1075	2490
Sp. 5	560	1650	2705	620	1340	2720	565	1375	2810
Sp. 6	500	1585	2500	455	1090	2445	500	1130	2395
Sp. 7	570	1380	2495	525	1100	2600	535	1080	2560
Sp. 8	600	1715	2700	575	1175	2725	565	1080	-
Sp. 9	<u>705</u>	<u>1670</u>	<u>2620</u>	<u>725</u>	<u>1200</u>	<u>2830</u>	<u>785</u>	<u>1165</u>	<u>2875</u>
Mean:	575	1595	2605	575	1185	2660	575	1160	2645
SD	66	99	96	76	87	158	85	93	207

T-tests:	CVC-ÇVC	CVC-ÇVC	ÇVC-ÇVC
F1	0.071 n.s.	0.124 n.s.	0.106 n.s.
F2	12.152 p<0.001	12.274 p<0.001	1.163 n.s.
F3	-1.461 n.s.	-0.949 n.s. (7 df)	0.313 n.s. (7 df)

3) /ii/

	CVVC			ÇVVC			ÇVVC		
	F1	F2	F3	F1	F2	F3	F1	F2	F3
Sp. 1	290	2250	2900	305	1765	2625	285	2020	2605
Sp. 2	260	2525	3065	315	2360	2910	290	2040	2765
Sp. 3	285	2210	2815	310	1875	2710	295	1915	2620
Sp. 4	310	2200	2940	335	1750	2665	295	1760	2455
Sp. 5	335	2200	3165	390	2125	3015	340	2040	3015
Sp. 6	300	1990	2765	365	1785	2490	300	1860	2440
Sp. 7	335	2310	3000	335	1900	2540	375	1750	2500
Sp. 8	310	2210	3085	415	1730	2845	395	1960	2920
Sp. 9	<u>290</u>	<u>2110</u>	<u>2775</u>	<u>390</u>	<u>1435</u>	<u>2425</u>	<u>400</u>	<u>1550</u>	<u>2435</u>
Mean:	300	2225	2945	350	1860	2690	330	1875	2640
SD:	24	145	144	40	261	199	48	165	216

T-tests:	CVVC-ÇVVC	CVVC-ÇVVC	ÇVVC-ÇVVC
F1	-4.042 p<0.01	-2.023 n.s.	1.966 n.s.
F2	5.807 p<0.001	6.164 p<0.001	-0.310 n.s.
F3	6.953 p<0.001	7.263 p<0.001	1.826 n.s.

4) /i/

	CVC			ÇVVC			ÇVVC		
	F1	F2	F3	F1	F2	F3	F1	F2	F3
Sp. 1	430	1905	2655	440	1420	2585	445	1520	2530
Sp. 2	365	1880	2720	445	1345	2895	400	1310	2860
Sp. 3	370	1915	2560	415	1440	2825	365	1775	2585
Sp. 4	460	1825	2520	475	1350	2545	450	1435	2455
Sp. 5	455	1935	2805	-	-	-	415	1855	2725
Sp. 6	465	1655	2405	460	1285	2280	430	1285	2385
Sp. 7	405	1935	2625	460	1365	2655	465	1490	2500
Sp. 8	395	2040	2740	465	1365	2300	435	1540	2780
Sp. 9	<u>380</u>	<u>1805</u>	<u>2500</u>	=	=	=	<u>400</u>	<u>1375</u>	<u>2585</u>
Mean:	415	1875	2615	450	1365	2585	425	1510	2600
SD:	40	108	129	20	51	236	31	195	157

T-tests	CVC-ÇVVC	CVC-ÇVVC	ÇVVC-ÇVVC
(6 df.)			
F1	-3.153 p<0.05	-0.783 n.s.	2.937 p<0.05
F2	14.271 p<0.001	6.914 p<0.001	-2.438 n.s.
F3	0.231 n.s.	0.447 n.s.	-0.016 n.s.

5) /uu/

	CVVC			ÇVVC			ÇVVCÇ		
	F1	F2	F3	F1	F2	F3	F1	F2	F3
Sp. 1	365	1150	2465	390	960	2535	335	975	2545
Sp. 2	325	1015	2535	310	835	2935	315	885	2920
Sp. 3	335	1335	-	350	965	2865	320	895	2600
Sp. 4	340	1310	2315	385	900	2550	295	835	2435
Sp. 5	385	1110	2275	385	1040	2250	390	1070	2515
Sp. 6	335	1015	2310	360	885	2550	325	890	2500
Sp. 7	385	1115	2290	400	990	2590	390	895	2775
Sp. 8	425	1120	2460	420	870	2940	400	840	2980
Sp. 9	<u>320</u>	<u>1150</u>	<u>2320</u>	<u>345</u>	<u>1080</u>	<u>2320</u>	<u>420</u>	<u>885</u>	=
Mean:	355	1145	2370	370	945	2615	355	910	2660
SD:	35	112	99	33	82	252	45	73	206

T-tests:	CVVC-ÇVVC	CVVC-ÇVVCÇ	ÇVVC-ÇVVCÇ
F1	-2.349 p<0.05	0.200 n.s.	1.129 n.s.
F2	4.879 p<0.01	4.954 p<0.01	1.548 n.s.
F3	-3.263 p<0.05 (7df)	-4.343 p<0.01(6df)	-0.117 n.s. (7 df)

6) /u/

	CVC			ÇVC			ÇVCÇ		
	F1	F2	F3	F1	F2	F3	F1	F2	F3
Sp. 1	430	1215	2445	450	1045	2455	455	1115	2390
Sp. 2	415	1140	2755	365	1000	-	455	1005	-
Sp. 3	315	1120	-	385	870	-	390	975	-
Sp. 4	415	1215	2365	455	940	2480	440	935	2490
Sp. 5	395	1115	2400	405	925	-	385	1055	-
Sp. 6	460	1175	2300	460	1000	2430	405	1020	2540
Sp. 7	385	1155	2375	445	925	-	460	1000	2565
Sp. 8	420	1325	2295	425	985	2620	430	970	-
Sp. 9	<u>400</u>	<u>1195</u>	<u>2445</u>	<u>405</u>	<u>1035</u>	=	<u>415</u>	<u>1000</u>	=
Mean:	405	1185	2420	420	970	2495	425	1010	2495
SD:	40	65	146	34	58	85	29	52	77

T-tests:	CVC-ÇVC	CVC-ÇVCÇ	ÇVC-ÇVCÇ
F1	-1.486 n.s.	-1.647 n.s.	0.329 n.s.
F2	9.931 p<0.001	5.800 p<0.001	-1.008 n.s.
F3	-2.208 n.s. (3 df)	-1.939 n.s. (3 df)	-0.362 n.s. (2 df)

7) /ee/

8) [e]

	CVVC			ÇVVC			CVC		
	F1	F2	F3	F1	F2	F3	F1	F2	F3
Sp. 1	325	1925	2735	400	1785	2650	385	1765	2665
Sp. 2	315	1900	2785	400	1625	2865	325	1800	2735
Sp. 3	365	1925	2535	425	1790	2690	385	1835	2570
Sp. 4	375	1840	2540	465	1625	2575	375	1725	2475
Sp. 5	360	1985	2885	400	2000	2900	390	1855	2735
Sp. 6	340	1735	2415	415	1485	2465	325	1655	2420
Sp. 7	400	1975	2565	435	1615	2615	450	1670	2475
Sp. 8	360	2000	2810	405	1805	2800	395	1860	2660
Sp. 9	<u>330</u>	<u>1820</u>	<u>2500</u>	<u>375</u>	<u>1220</u>	<u>2525</u>	<u>350</u>	<u>1775</u>	<u>2500</u>
Mean:	350	1900	2640	415	1660	2675	375	1770	2580
SD:	27	88	164	26	223	151	39	76	120

T-test:	CVVC-ÇVVC	[i-e], CVC
F1	-8.843 p<0.001	2.074 n.s.
F2	4.200 p<0.01	3.987 p<0.01
F3	-1.615 n.s.	1.699 n.s.

9) /oo/

10) [o]

	CVVC			ÇVVC			CVC		
	F1	F2	F3	F1	F2	F3	F1	F2	F3
Sp. 1	435	1310	2500	435	1010	2440	465	1205	2400
Sp. 2	415	1265	-	415	935	2910	415	1265	2535
Sp. 3	440	1315	2175	400	1040	2800	425	1210	2350
Sp. 4	435	1300	2310	390	915	2540	470	1285	2320
Sp. 5	385	1270	2390	400	1000	2590	420	1205	2650
Sp. 6	410	1365	2425	410	975	2475	425	1295	2325
Sp. 7	465	1365	2490	415	1050	2525	500	1260	2415
Sp. 8	415	1355	2500	440	1085	-	435	1435	-
Sp. 9	<u>365</u>	<u>1320</u>	<u>2090</u>	<u>355</u>	<u>860</u>	<u>2760</u>	<u>435</u>	<u>1420</u>	<u>2215</u>
Mean:	420	1320	2360	405	985	2630	445	1285	2400
SD:	30	38	156	25	72	171	29	87	136

T-test	CVVC-ÇVVC	[u-o], CVC
F1	1.294 n.s.	-2.436 p<0.05
F2	15.135 p<0.001	-5.043 p<0.01
F3	-2.286 n.s. (6 df)	0.516 n.s. (6 df)

TABLE 5
FORMANTS, CENTER FREQUENCIES

Mean of three tokens for each speaker, grand mean, standard deviation and t-tests

1) /aa/

	CVVC			ÇVVC			ÇVVCÇ		
	F1	F2	F3	F1	F2	F3	F1	F2	F3
Sp. 1	540	1740	2660	600	1050	2360	575	1095	2325
Sp. 2	650	1740	2740	615	1090	2950	645	1115	2935
Sp. 3	585	1825	2585	615	1040	2795	620	1055	2740
Sp. 4	565	1840	2510	600	1025	2560	605	985	2380
Sp. 5	560	1760	2740	615	1185	2825	615	1215	2685
Sp. 6	505	1650	2500	550	1160	2465	540	1085	2410
Sp. 7	565	1785	2500	585	975	2725	570	935	2440
Sp. 8	555	1945	2740	730	1125	2765	640	1125	-
Sp. 9	<u>730</u>	<u>1715</u>	<u>2640</u>	<u>700</u>	<u>1065</u>	<u>2825</u>	<u>765</u>	<u>1180</u>	<u>2815</u>
Mean:	585	1780	2625	625	1080	2695	620	1090	2590
SD:	67	85	104	56	67	193	64	88	229

T-tests:	CVVC-ÇVVC	CVVC-ÇVVC	ÇVVC-ÇVVCÇ
F1	-1.935 n.s.	-4.097 p<0.01	0.278 n.s.
F2	17.726 p<0.001	15.480 p<0.001	-0.445 n.s.
F3	-1.296 n.s.	0.358 n.s. (7 df)	2.800 p<0.05 (7df)

2) /a/

	CVC			ÇVC			ÇVCÇ		
	F1	F2	F3	F1	F2	F3	F1	F2	F3
Sp. 1	555	1595	2560	585	1185	2440	585	1160	2360
Sp. 2	595	1625	2735	645	1275	2845	660	1195	2805
Sp. 3	620	1520	2565	645	1075	2885	575	1140	2875
Sp. 4	660	1495	2475	660	1085	2500	675	1085	2515
Sp. 5	565	1715	2785	640	1340	2735	565	1295	2780
Sp. 6	515	1550	2575	555	1075	2410	605	1115	2395
Sp. 7	650	1440	2500	600	1145	2680	600	1120	2490
Sp. 8	645	1675	2695	635	1125	2755	595	1155	-
Sp. 9	<u>730</u>	<u>1650</u>	<u>2660</u>	<u>765</u>	<u>1245</u>	<u>2835</u>	<u>760</u>	<u>1135</u>	<u>2925</u>
Mean:	615	1585	2615	635	1170	2675	625	1155	2645
SD.	65	90	107	59	96	182	63	61	227

T-tests	CVC-ÇVC	CVC-ÇVCÇ	ÇVC-ÇVCÇ
F1	-1.765 n.s.	-0.559 n.s.	0.884 n.s.
F2	16.880 p<0.001	20.875 p<0.001	0.877 n.s.
F3	-1.145 n.s.	-0.560 n.s. (7 df)	0.770 n.s. (7 df)

3) /ii/

	CVVC			ÇVVC			ÇVVCÇ		
	F1	F2	F3	F1	F2	F3	F1	F2	F3
Sp. 1	265	2300	2900	300	2125	2650	300	2150	2630
Sp. 2	260	2685	3115	265	2500	2965	255	2405	2815
Sp. 3	290	2360	3025	310	2110	2850	295	2215	2725
Sp. 4	325	2385	3115	315	2200	2865	295	2180	2680
Sp. 5	315	2240	3240	350	2275	3115	335	2200	3115
Sp. 6	315	2085	2815	340	2000	2590	350	2015	2485
Sp. 7	325	2460	3200	315	2290	2665	365	2210	2750
Sp. 8	310	2550	3275	360	2405	2995	375	2325	3045
Sp. 9	<u>250</u>	<u>2235</u>	<u>2955</u>	<u>335</u>	<u>2240</u>	<u>2925</u>	<u>360</u>	<u>2125</u>	<u>2740</u>
Mean:	295	2365	3070	320	2240	2845	325	2200	2775
SD:	30	181	159	29	153	178	41	112	196

T-tests:	CVVC-ÇVVC	CVVC-ÇVVCÇ	ÇVVC-ÇVVCÇ
F1	-2.595 p<0.05	-2.246 n.s.	-0.580 n.s.
F2	4.065 p<0.01	5.988 p<0.001	1.480 n.s.
F3	4.814 p<0.01	8.583 p<0.001	2.079 n.s.

4) /i/

	CVC			ÇVC			ÇVCÇ		
	F1	F2	F3	F1	F2	F3	F1	F2	F3
Sp. 1	455	1885	2605	445	1385	2575	465	1505	2500
Sp. 2	380	1930	2495	475	1395	2890	425	1315	2855
Sp. 3	410	1935	2590	445	1530	2855	365	1810	2630
Sp. 4	475	1845	2525	485	1435	2535	455	1520	2465
Sp. 5	465	1955	2810	-	-	-	405	1825	2720
Sp. 6	485	1725	2480	485	1410	2345	440	1305	2395
Sp. 7	425	2010	2680	515	1455	2605	495	1575	2495
Sp. 8	425	2085	2775	460	1345	2340	445	1560	2785
Sp. 9	<u>400</u>	<u>1865</u>	<u>2535</u>	=	=	=	<u>430</u>	<u>1425</u>	<u>2555</u>
Mean:	435	1915	2610	475	1420	2590	435	1540	2600
SD:	36	103	123	25	59	218	37	186	157

T-tests:	CVC-ÇVC	CVC-ÇVCÇ	ÇVC-ÇVCÇ
F1	-2.306 n.s. (6 df)	-0.037 n.s.	2.644 p<0.05 (6df)
F2	9.531 p<0.001 (6df)	6.904 p<0.001	-1.694 n.s. (6 df)
F3	-0.021 n.s. (6 df)	0.203 n.s.	0.035 n.s. (6 df)

5) /uu/

	CVVC			ÇVVC			ÇVVĊ		
	F1	F2	F3	F1	F2	F3	F1	F2	F3
Sp. 1	285	840	2435	310	810	2570	300	855	2505
Sp. 2	290	755	2650	300	710	2965	300	725	2970
Sp. 3	295	675	-	300	665	-	310	710	2700
Sp. 4	295	870	2310	330	830	2420	310	875	2485
Sp. 5	310	790	-	355	780	-	325	775	-
Sp. 6	310	870	2280	310	810	2580	305	820	2565
Sp. 7	315	750	2335	355	790	-	375	820	-
Sp. 8	345	780	-	360	720	-	380	765	-
Sp. 9	<u>290</u>	<u>785</u>	<u>2225</u>	<u>340</u>	<u>785</u>	<u>-</u>	<u>360</u>	<u>830</u>	<u>-</u>
Mean:	305	790	2375	330	765	2635	330	795	2645
SD:	17	63	153	25	55	233	33	57	198

T-tests:	CVVC-ÇVVC	CVVC-ÇVVĊ	ÇVVC-ÇVVĊ
F1	-4.082 p<0.01	-3.107 p<0.05	-0.090 n.s.
F2	2.213 n.s.	-0.520 n.s.	-4.756 p<0.01
F3	-4.001 p<0.05(3 df)	-3.750 p<0.05(3 df)	0.093 n.s. (3 df)

6) /u/

	CVC			ÇVC			ÇVĊ		
	F1	F2	F3	F1	F2	F3	F1	F2	F3
Sp. 1	425	1180	2360	465	995	2445	485	1085	2340
Sp. 2	435	1120	2795	420	1000	-	475	960	-
Sp. 3	355	1235	-	440	930	-	415	945	-
Sp. 4	425	1025	2400	455	890	2465	465	880	2450
Sp. 5	405	1045	2475	425	965	-	435	985	-
Sp. 6	480	1125	2310	485	995	2465	435	1025	2500
Sp. 7	375	1010	2395	485	825	-	475	995	2555
Sp. 8	425	1265	2300	435	915	2660	460	955	-
Sp. 9	<u>410</u>	<u>1095</u>	<u>2390</u>	<u>440</u>	<u>965</u>	<u>-</u>	<u>435</u>	<u>875</u>	<u>-</u>
Mean:	415	1120	2430	450	940	2510	455	965	2460
SD:	36	90	158	24	58	101	24	66	92

T-tests:	CVC-ÇVC	CVC-ÇVĊ	ÇVC-ÇVĊ
F1	-2.662 p<0.05	-2.975 p<0.05	-0.104 n.s.
F2	5.982 p<0.001	4.597 p<0.01	-1.028 n.s.
F3	-2.466 n.s. (3 df)	-1.949 n.s. (3 df)	0.692 n.s. (2 df)

7) /ee/

8) [e]

	CVVC			ÇVVC			CVC		
	F1	F2	F3	F1	F2	F3	F1	F2	F3
Sp. 1	390	2125	2765	400	2040	2660	465	1825	2680
Sp. 2	350	2415	2860	375	2300	2865	380	1960	2780
Sp. 3	365	2275	2750	415	2190	2790	440	1930	2600
Sp. 4	425	2165	2735	460	1985	2610	475	1845	2535
Sp. 5	365	2235	3115	365	2190	3000	435	1925	2800
Sp. 6	385	1900	2510	425	1875	2485	420	1745	2465
Sp. 7	415	2310	2760	450	1960	2690	495	1885	2485
Sp. 8	355	2400	2975	395	2245	2880	420	2050	2820
Sp. 9	<u>410</u>	<u>2115</u>	<u>2755</u>	<u>420</u>	<u>2100</u>	<u>2635</u>	<u>390</u>	<u>1915</u>	<u>2595</u>
Mean:	385	2215	2800	410	2100	2735	435	1895	2640
SD:	28	161	169	32	143	161	38	87	136

T-tests:	CVVC-ÇVVC	[i-e], CVC
F1	-4.811 p<0.01	0.000 n.s.
F2	3.396 p<0.01	0.974 n.s.
F3	3.371 p<0.01	-0.770 n.s.

9)/oo/

10) [o]

	CVVC			ÇVVC			CVC		
	F1	F2	F3	F1	F2	F3	F1	F2	F3
Sp. 1	435	985	2415	435	910	2440	495	1215	2285
Sp. 2	390	860	-	415	825	3025	425	1195	2655
Sp. 3	400	850	-	375	890	2600	415	1025	2340
Sp. 4	425	890	2265	400	835	2490	495	1185	2240
Sp. 5	400	810	2450	385	785	2625	405	1060	2600
Sp. 6	385	935	2390	410	925	2490	465	1195	2245
Sp. 7	410	850	2515	425	810	2875	480	1010	2435
Sp. 8	405	905	-	375	785	-	445	1210	-
Sp. 9	<u>390</u>	<u>815</u>	<u>2465</u>	<u>365</u>	<u>835</u>	<u>2755</u>	<u>410</u>	<u>1175</u>	<u>2390</u>
Mean:	405	880	2415	400	845	2665	450	1140	2400
SD:	17	57	86	25	52	207	36	84	157

T-tests:	CVVC-ÇVVC	[u-o], CVC
F1	0.806 n.s.	-2.298 n.s.
F2	2.074 n.s.	-0.541 n.s.
F3	-3.904 0.05 (5 df)	1.027 n.s. (6 df)

BIBLIOGRAPHY

Abbreviations:

JASA	Journal of the Acoustical Society of America.
RUUL	Reports from Uppsala University, Department of Linguistics.
STL-QPSR	Speech Transmission Laboratory-Quarterly Progress and Status Report.
ZDMG	Zeitschrift der Deutschen Morgenländischen Gesellschaft.

- Abboud, P. et al. 1968. *Introduction to Modern Standard Arabic Pronunciation and Writing*. Ann Arbor, Michigan.
- Abdel-Massih, E. 1975. *An Introduction to Egyptian Arabic*. Ann Arbor, The University of Michigan.
- Aboul-Fetouh, H. 1969. *A Morphological Study of Egyptian Colloquial Arabic*. Mouton, The Hague and Paris.
- Abramson, A. 1960. *The Vowels and Tones of Standard Thai: Acoustical Measurements and Experiments*. PhD dissertation, Columbia University.
- Adem, S.A. 1983. Are the emphatic consonants of Egyptian Arabic rounded? An experimental investigation of rounding and lip-protrusion. *RUUL* 11.
- Al-Ani, S.H. 1970. *Arabic Phonology. An Acoustic and Physiological Investigation*. Mouton, The Hague and Paris.
- Al-Ani, S.H. and El-Dalee, M.S. 1983. Tafkhim in Arabic: The Acoustic and Psychological Parameters. *Abstracts of the Tenth International Congress of Phonetic Sciences*, IIB:385-389.
- Ali, L.H. and Daniloff, R.G. 1972. A contrastive cinefluorographic investigation of the articulation of emphatic-non-emphatic cognate consonants. *Studia Linguistica*, 26/11:81-105.
- Altoma, S. 1969. *The Problem of Diglossia in Arabic. A Comparative Study of Classical and Iraqi Arabic*. Harvard Middle Eastern Monographs XXI. Harvard University Press, Cambridge, Mass.
- Bakalla, M.H. 1984. *Arabic culture through its language and literature*. Kegan Paul International, London, Boston, Melbourne and Henley.
- Beeston, A.F.L. 1970. *The Arabic Language Today*. Hutchinsons & Co, London.
- Birkeland, H. 1952. Growth and structure of the Egyptian Arabic Dialect. *Avhandlingar utgitt av Det Norske Videnskaps-Akademi i Oslo*. II.Hist-filos. klasse, 1952, No.1.
- Blanc, H. 1959. Richard S. Harrell. The Phonology of Colloquial Egyptian Arabic. In *Word*, 15:2.
- Boff-Dkhissi, M-C. 1983. Contribution a l'étude expérimentale des consonnes d'arrière de l'arabe classique. *Travaux de l'institut de phonétique*, Strasbourg.

- Broselow, E.I. 1976. *The Phonology of Egyptian Arabic*. PhD dissertation, University of Massachusetts.
- Cantineau, J. 1960. *Cours de phonétique arabe*. Librairie de Klincksieck, Paris.
- Card, E.A. 1983. *A Phonetic and Phonological Study of Arabic Emphasis*. PhD dissertation, Cornell University.
- Catford, J.C. 1982. *Fundamental Problems in Phonetics*. Indiana University Press, Bloomington.
- Cejne, A. 1969. *The Arabic Language. Its Role in History*. University of Minnesota Press, Minneapolis.
- Chomsky, N. and Halle, M. 1968. *The Sound Pattern of English*. New York: Harper & Row.
- Cowell, M. 1964. *A Reference Grammar of Syrian Arabic*. Arabic Series: No 7. Georgetown University Press, Washington D.C.
- Delattre, P.C., Liberman, A.M. and Cooper, F.S. 1955. Acoustic Loci and Transitional Cues for Consonants. *JASA*, 27:4, 769-773.
- Denes, P. 1955. Effect of duration on the perception of voicing. *JASA*, 27:4, 761-764.
- Denes, P. and Pinson, E. 1973. *The Speech Chain: The Physics and Biology of Spoken Language*. Anchor Books, New York.
- Diem, W. 1974. *Hochsprache und Dialekt im Arabischen. Untersuchungen zur heutigen arabischen Zweisprachigkeit*. Kommissionsverlag Franz Steiner, Wiesbaden.
- Drozdk, L. 1973. The vowel system of Egyptian Colloquial Arabic. *Asian and African Studies* IX, Bratislava, London.
- Disner, S.F. 1980. Evaluation of vowel normalisation procedures. *JASA*, 67(1):253-261.
- Durand, M. 1946. *Voyelles longues et voyelles brèves: essai sur la nature de la quantité vocalique*. Collection linguistique, Société Linguistique de Paris, XLIX. Librairie C. Klincksieck, Paris.
- Elert, C-C. 1964. *Phonologic Studies of Quantity in Swedish*. Almqvist & Wiksells, Uppsala.
- El-Hajjé, H. 1954. *Le parler arabe de Tripoli (Liban)*. Librairie C. Klincksieck, Paris.
- El-Halees, Y. 1985. The role of F1 in the place-of-articulation distinction in Arabic. *Journal of Phonetics*, 13:287-298.
- Engstrand, O. 1986. Durational correlates of quantity and sentence stress: a cross-linguistic study of Swedish, Finnish and Czech. *UCLA Working Papers*, 86:1-25.
- Erwin, W. 1963. *A Short Reference Grammar of Iraqi Arabic*. Georgetown University Press, Washington D.C.
- Ferguson, C.A. 1959. Diglossia. *Word*, 15: 325-340.
- Fischer, W. and Jastrow, O. 1980. (Eds.) *Handbuch der arabischen Dialekte*. Harrassowitz, Wiesbaden.
- Flege, J.E. 1981. Cross-language phonetic interference: Arabic to English. *Language and Speech*, 24:2, 125-146.
- Fleisch, H. 1961. *Traité de philologie arabe*. Vol. 1. Imprimerie Catholique, Beyrouth.

- Fre Woldu, K. 1981. Facts regarding Arabic emphatic consonant production. *RUUL*, 7.
- Fre Woldu, K. 1986. Evidence of Auditory Similarity between Tigrinya Ejective /t/ and Arabic Emphatic /t̤/. In *Orientalia Suecana XXXIII-XXXV 1984-1986*, pp. 123-138. Almqvist & Wiksell International, Stockholm.
- Gairdner, W.H.T. 1925. *The Phonetics of Arabic*. Oxford University Press.
- Gamal-Eldin, S. 1967. *A Syntactic Study of Egyptian Colloquial Arabic*. Mouton, The Hague and Paris.
- Ghazeli, S. 1977. *Back Consonants and Backing Coarticulation in Arabic*. PhD dissertation, University of Texas, Austin.
- Giannini, A. and Pettorino, M. 1982. The emphatic consonants in Arabic. *Speech Laboratory Report IV*. Istituto Universitario Orientale, Napoli.
- Grotzfeld, H. 1965. Syrisch-Arabische Grammatik (Dialekt von Damaskus). *Porta Linguarum Orientalium, neue Serie VIII*. Harrassowitz, Wiesbaden.
- Hadding-Koch, K. and Abramson, A. 1964. Duration versus Spectrum in Swedish Vowels: some Perceptual Experiments. *Studia Linguistica XVIII:II*, Gleerup, Lund.
- Hamzaoui, R. 1965. *L'académie arabe de Damas et le probleme de la modernisation de la langue arabe*. Brill, Leiden.
- Harrell, R.S. 1955. *The phonology of colloquial Egyptian Arabic*. New York: American council of learned societies.
- Harrell, R.S. 1962. *A Short Reference Grammar of Moroccan Arabic*. Georgetown University Press, Washington.
- Harrell, R.S., Tewfik, L. and Selim, G. 1963. *Lessons in Colloquial Egyptian Arabic*. Arabic Series: 2. Georgetown University Press, Washington D.C.
- Hughes, G.W. and Halle, M. 1956. Spectral Properties of Fricative Consonants. *JASA* 28:2.
- Johnstone, T.M. 1967. *Eastern Arabian Dialect Studies*. London, Oxford University Press.
- Jomier, J. 1964. *Manuel d'arabe égyptien*. Paris: Librairie C. Klincksieck.
- Kahn, M. 1975. Arabic emphatics: The evidence for cultural determinants of phonetic sex-typing. *Phonetica*, 31; 38-50.
- Khalafallah, A. 1967. A descriptive grammar of Saʿī:di Egyptian colloquial Arabic. *Janua Linguarum, Series Practica* 32. Mouton, The Hague and Paris.
- Kropfitch, L. 1978. Der französische Einfluss auf die Arabische Schriftsprache in Maghrib. *ZDMG*, 128:1, 39-64.
- Kuriyagawa, F., Sawashima, M., Niimi, S. and Hirose, H. 1986. An Electromyographic Study of the Emphatic Consonants in Standard Jordanian Arabic. *Logopedics and Phoniatrics*, Annual Bulletin no. 20. University of Tōkyō.
- Ladefoged, P. 1982. *A Course in Phonetics*. Harcourt, Brace, Jovanovich, New York.

- Ladefoged, P. 1985. Macintosh models and plots for phoneticians. *UCLA Working Papers in Phonetics*, 61:65-71.
- Ladefoged, P. and Maddieson, I. 1986. Some of the Sounds of the World's Languages: (Preliminary version). *UCLA Working Papers in Phonetics*, 64.
- Lehiste, I. 1970. *Suprasegmentals*. The M.I.T. Press.
- Lehn, W. 1963. Emphasis in Cairo Arabic. *Language*, 39:2.
- Lehtonen, J. 1970. *Aspects of quantity in Standard Finnish*. K.J. Gummerus, Jyväskylä.
- Leslau, W. 1957. The Semitic Phonetic System. In *Manual of Phonetics* (ed. L. Kaiser). North-Holland Publishing Company, Amsterdam.
- Liljencrants, J. and Lindblom, B. 1972. Numerical simulation of vowel quality systems: The role of perceptual contrast. *Language* 48; 839-862.
- Liljencrants, J. and Fant, G. 1975. Computer program for VT-resonance frequency calculations. *STL-QPSR*, 4:15-20. Stockholm.
- Lindau, M. 1985. Features for Vowels. *UCLA Working Papers in Phonetics*, 30.
- Lindau, M. 1985. Hausa vowels and diphthongs. *Studies in African Linguistics*, 16:2.
- Lindblom, B. 1963. Spectrographic Study of Vowel Reduction. *JASA*, 35:11;1773-1781.
- Lindblom, B. 1967. Vowel duration and a model of lip mandible coordination. *STL-QPSR*, 4:1-29. Stockholm.
- Löfqvist, A. 1976. Closure duration and aspiration for Swedish stops. *Working Papers* 13. Department of Linguistics, Lund University.
- Maack, A. 1949. Die spezifische Lautdauer deutscher Sonanten. *Zeitschrift für Phonetik* 3, pp. 190-232.
- Magdics, K. 1969. *Studies in the Acoustic Characteristics of Hungarian Speech Sounds*. Mouton & Co., The Hague.
- Malmberg, B. 1944. *Die Quantität als phonetisch-phonologischer Begriff. Eine allgemeinsprachliche Studie*. Gleerups, Lund.
- Marçais, P. 1948. *Articulation de l'emphase dans un parler maghrébin*. Alger.
- Mattsson, E. 1910. *Etudes phonologiques sur le dialect vulgaire de Beyrouth*, Upsala.
- Mitchell, T.F. 1978. In *Introduction to Egyptian Colloquial Arabic*. Oxford University Press.
- Monteil, V. 1960. *L'arabe moderne*. Librairie C. Klincksieck, Paris.
- Moscatti, S., Spitaler, A., Ullendorff, E., von Soden, W. 1969. *An Introduction to the Comparative Grammar of the Semitic Languages*. Harrassowitz, Wiesbaden.
- Nartey, J.N.A. 1982. On Fricative Phones and Phonemes: Measuring the Phonetic Differences Within and Between Languages. *UCLA Working Papers* 55.
- Nasr, R. 1966. *Colloquial Arabic. An Oral Approach*. Librairie de Liban, Beirut.

- Norlin, K. 1983. Acoustic analysis of fricatives in Cairo Arabic. *Working Papers*, 25:113-137. Department of Linguistics, Lund University.
- Nooteboom, S.G. 1972. *Production and perception of vowel duration. A study of durational properties of vowels in Dutch.*
- Obrecht, D.H. 1968. *Effects of the second formant on the perception of velarization consonants in Arabic.* Mouton, The Hague & Paris.
- Omar, M. 1973. *The Acquisition of Egyptian Arabic as a Native Language.* Janua Linguarum, Series Practica, 160. Mouton, The Hague and Paris.
- Palva, H. 1966. *Lower Galilean Arabic. An Analysis of Its Anaptyctic and Prothetic Vowels with Sample Texts.* Helsinki.
- Palva, H. 1976. *Studies in the Arabic Dialect of the Semi-Nomadic al-ʿAǧārma Tribe (al-Balqāʿ District, Jordan).* *Orientalia Gothoburgensia* 2.
- Palva, H. 1980. Characteristics of the Arabic Dialect of the Bani Ṣaxar Tribe. *Orientalia Suecana* 29: 112-139.
- Palva, H. 1986. Characteristics of the Arabic Dialect of the Ḥwēṭāt Tribe. *Orientalia Suecana* XXXIII-XXXV (1984-86; 295-312).
- Port, R.F., Al-Ani S. and Maeda, S. 1980. Temporal compensation and universal phonetics. *Phonetica* 37:235-266.
- Port, R. and Mittleb, F. 1980. Phonetic and phonological manifestations of the voicing contrast in Arabic-accented English. *Research in Phonetics*, 1: 137-165. Dept. of Linguistics, Indiana University.
- Prasse, K-G. 1971. In Hassan, M.I. *In-nas wil-malik. People and King. Folk Tales in the Cairene Dialect in Roman Transcription.* Copenhagen University Publications Fund, Copenhagen.
- Rice, F. and Said, M. 1960. *Eastern Arabic. An Introduction to the Spoken Arabic of Palestine, Syria and Lebanon.* Khayat's, Beirut.
- Salib, M.B. 1982. *Spoken Arabic of Cairo.* The American University in Cairo, Cairo.
- Schroeder, M.R., B.S. Atal and J.L. Hall. 1979. Objective measure of certain speech signal degradations based on masking properties of human auditory perception. In Björn Lindblom and Sven Öhman, ed. *Frontiers of speech communication research*, London: Academic Press 1979, pp. 217-229.
- Spitta-Bey, W. 1880. *Grammatik des arabischen Vulgärdialectes von Aegypten.* Leipzig.
- Stetkevych, J. 1970. *The Modern Arabic Literary Language. Lexical and Stylistic Developments.* The university of Chicago Press, Chicago & London.
- Stevens, K.N. and Klatt, D. 1969. Pharyngeal Consonants. *Research Laboratory of Electronics M.I.T. Quarterly Progress Report* 93, pp. 208-216.
- Svantesson, J-O. 1984. Acoustic analysis of Chinese fricatives and affricates. *Journal of Chinese Linguistics* (Berkeley) 14, 53-70.
- Talmoudi, F. 1979. *The Arabic Dialect of Susa (Tunisia).* *Orientalia Gothoburgensia* 4.

- Talmoudi, F. 1984. *The Diglossic Situation in North Africa: A Study of Classical Arabic/Dialectal Arabic Diglossia with Sample Texts in 'Mixed Arabic'*. *Orientalia Gothoburgensia* 8.
- Tomiche, N. 1964. *Le parler arabe du Caire*. Mouton, Paris & La Haye.
- Wiik, K. 1965. *Finnish and English Vowels*. Turku.
- Willms, A. 1972. *Einführung in das Vulgärarabische von Nordwestafrika*. Brill, Leiden.
- Wise, H. 1975. *A Transformational Grammar of Spoken Egyptian Arabic*. Publications of the Philological Society XXVI, Blackwell, Oxford.
- Wodarz, H.W. 1970. *Beiträge zur Phonetik des Tschechischen*. Helmut Buske Verlag, Hamburg.
- Woidich, M. 1980. Das Ägyptisch-Arabische. In *Handbuch der arabischen Dialekte*, ed. Fischer, W. and Jastrow, O. *Porta linguarum orientalium*, neue Serie XVI. Harrassowitz, Wiesbaden.
- Wood, S. 1982 X-ray and model studies of vowel articulation. *Working Papers* 23. Department of Linguistics, Lund University.
- Ziadeh, F.J. and Winder, R.B. 1966. *An Introduction to Modern Arabic*. Princeton University Press, Princeton